

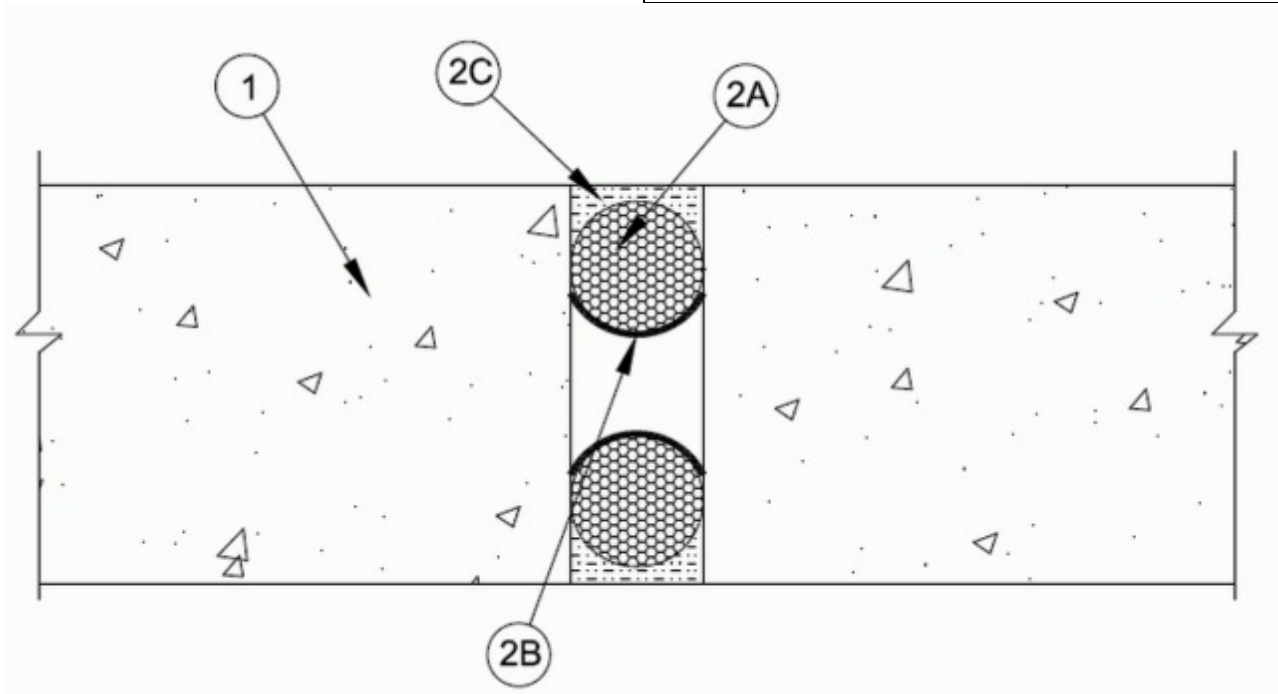

### System No. WW-D-0110

September 04, 2012

ANSI/UL2079	CAN/ULC S115
Assembly Rating — 2 Hr	F Rating — 2 Hr
Nominal Joint Width — 2 in.	FT Rating — 2 Hr
Class II or III Movement Capabilities — 25 % Compression or Extension	FH Rating — 2 Hr
	FTH Rating — 2 Hr
	Nominal Joint Width — 51 mm
	Class II or III Movement Capabilities — 25 % Compression or Extension



1. **Wall Assembly** — Min 6 in. (152 mm) thick reinforced lightweight or normal weight (100-150 pcf 1600-2400 kg/m<sup>3</sup>) structural concrete.

2. **Joint System** — Max width of joint (at time of installation of joint system) is 2 in. (51 mm). The joint system is designed to accommodate a max 25 percent compression or extension from it's installed width. The joint system shall consist of the following:

A. **Fill, Void or Cavity Material\* — Joint Strip** — Nom 1/16 in. (1.6 mm) thick by 4 in. (102 mm) wide strip of intumescent material faced on one side with an elastomeric backing strip. Strip is formed into a "u-shape " along its length and friction fit into joint opening such that the base of the "u" is recessed approximately 1-9/16 in. (39 mm) from one surface (either side) of wall.

**RECTORSEAL** — Metacaulk Joint Strip, Biostop Joint Strip or FlameSafe Joint Strip

B. **Packing Material** — Foam backer rod firmly packed into opening as a permanent form. Packing material to be recessed from both surfaces of wall as required to accommodate the required thickness of fill material.

**C. Fill, Void or Cavity Material\*** — Caulk - Min 1/4 in. (6 mm) thickness of fill material applied within the joint, flush with each surfaces of wall.

**BASF CONSTRUCTION CHEMICAL L L C** — Sonolastic NP-1 Caulk

**RECTORSEAL** — Metacaulk 1000, 150+, 350i, 835+, 1200, Biostop 500+, 150+, 350i, 100, 800, 750, FlameSafe 900+, 1900, 4000.

**SIKA CORPORATION** — Sikaflex 2C NS, Sikaflex 1-A

\*Bearing the UL Classification Mark