



System No. W-L-2460

September 26, 2005

F Ratings — 1 and 2 Hr (See Item 1)

T Ratings — 1 and 1-3/4 Hr (See Item 1)

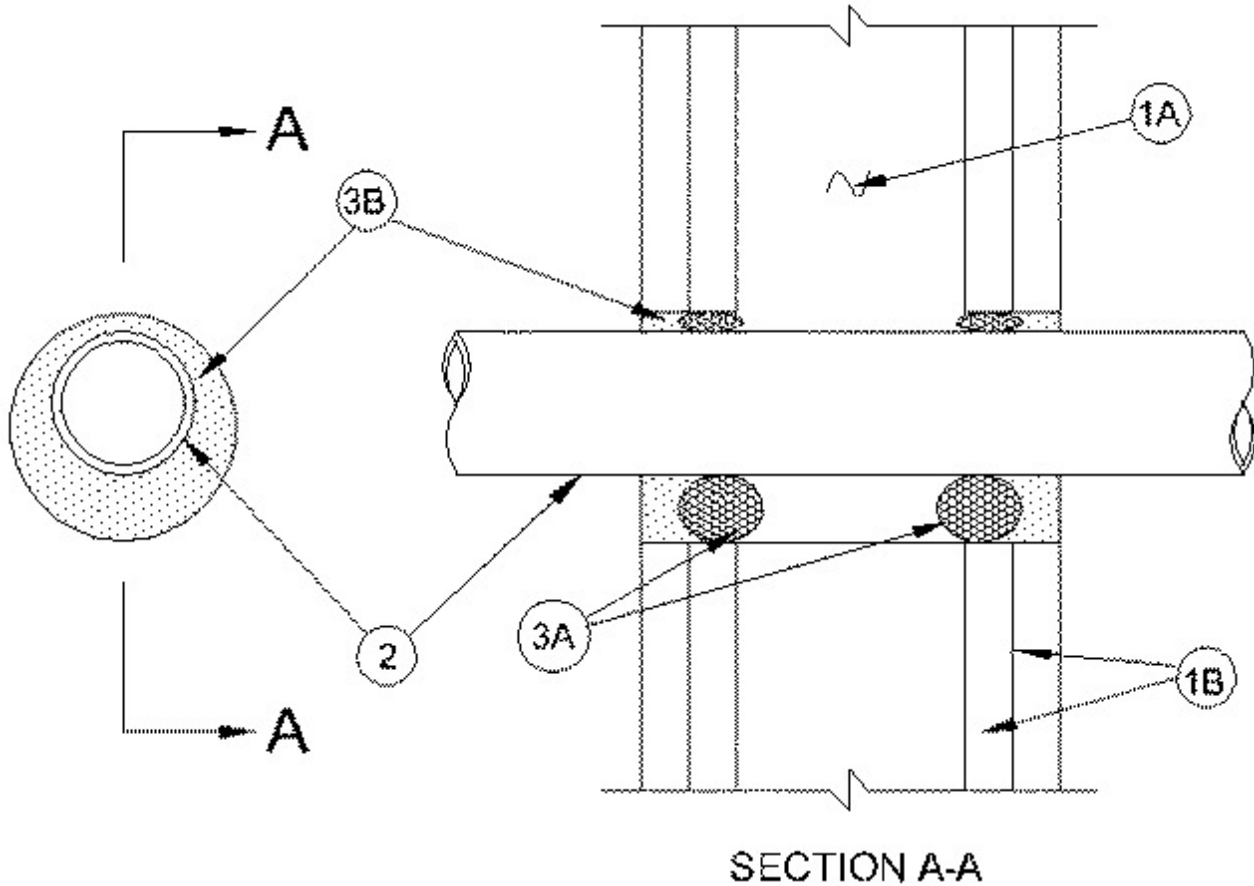

1. Wall Assembly — The 1 or 2 hr fire-rated gypsum wallboard/stud wall assembly shall be constructed of the materials and in the manner specified in the individual U300, U400 or V400 Series Wall and Partition Designs in the UL Fire Resistance Directory and shall include the following construction features:

A. Studs — Wall framing may consist of either wood studs or steel channel studs. Wood studs to consist of nom 2 by 4 in. (51 by 102 mm) lumber spaced 16 in. OC (406 mm). Steel studs to be min 3-1/2 in. (89 mm) wide and spaced max 24 in. OC (610 mm).

B. Gypsum Board* — The gypsum board type, thickness, number of layers and orientation shall be, as specified in the individual Wall and Partition Design. Max diam of opening is 3 in. (76 mm).

The hourly F Ratings of the firestop system is equal to the hourly fire rating of the wall assembly in which it is installed. When the F Rating is 1 hr, the T Rating is 1 hr. When the F Rating is 2 hr, the T Rating is 1-3/4 hr.

2. Through Penetrants — One nonmetallic pipe to be installed concentrically or eccentrically within the firestop system. The annular space between the nonmetallic pipe and the periphery of opening shall be min 1/4 in. (6 mm) to max 7/8 in. (22 mm). Pipe to be rigidly supported on both sides of wall assembly. The following types and sizes of nonmetallic pipes may be used:

A. Polyvinyl Chloride (PVC) Pipe — Nom 1-1/2 in. (38 mm) diam (or smaller) Schedule 40 cellular or solid core PVC pipe for use in closed (process or supply) or vented (drain, waste or

vent) piping systems.

B. Chlorinated Polyvinyl Chloride (CPVC) Pipe — Nom 1-1/2 in. (38 mm) diam (or smaller) SDR 13.5 CPVC pipe for use in closed (process or supply) piping systems.

C. Acrylonitrile Butadiene Styrene (ABS) Pipe — Nom 1-1/2 in. (38 mm) diam (or smaller) Schedule 40 cellular or solid core ABS pipe for use in closed (process or supply) or vented (drain, waste or vent) piping systems.

3. Fill, Void or Cavity Material* — The firestop system shall consist of the following:

A. Packing Material — In 2 hr assemblies, foam backer rod firmly packed into opening as a permanent form. Packing material is to be recessed from both surfaces of wall as required to accommodate the required thickness of fill material.

B. Caulk — Min 1/2 in. (13 mm) thickness of fill material applied within the annulus flush with both surfaces of wall.

RECTORSEAL — Biostop 350i

*Bearing the UL Classification Mark