

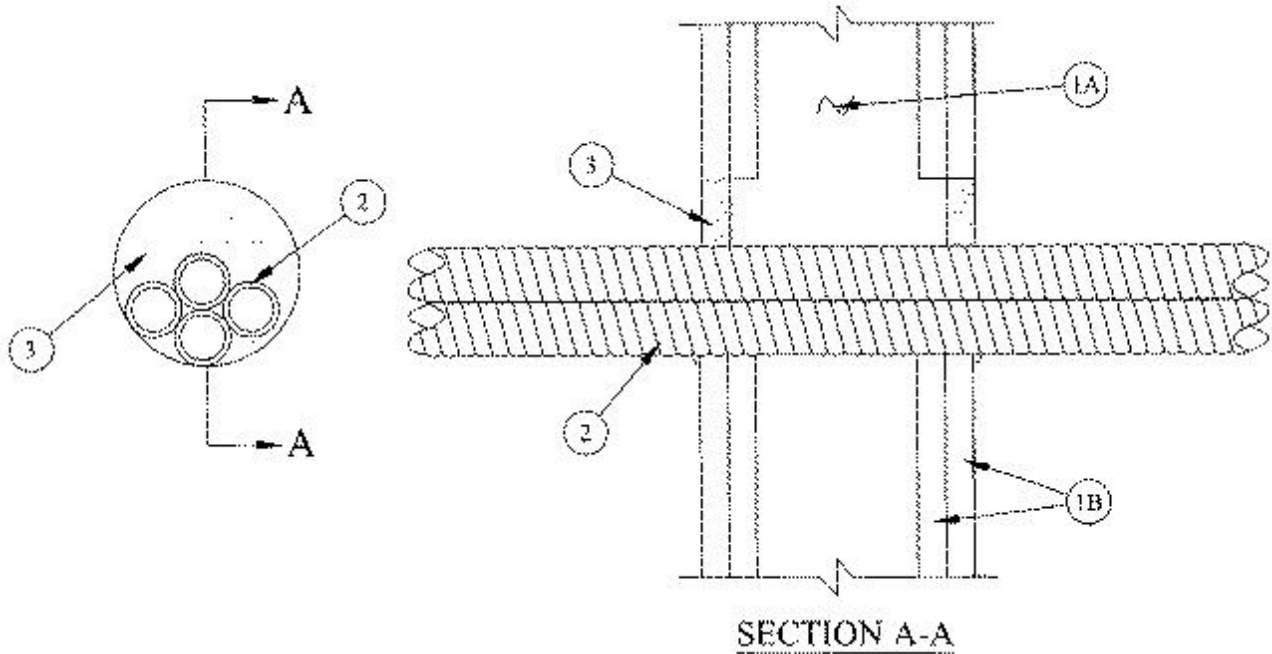

System No. W-L-1204

February 05, 2014

ANSI/UL1479 (ASTM E814)	CAN/ULC S115
F Rating — 1 and 2 Hr (See Item 1)	F Rating — 1 and 2 Hr (See Item 1)
T Rating — 0 Hr	FT Rating — 0 Hr
L Rating At Ambient — Less Than 1 CFM/sq ft	FH Rating — 1 and 2 Hr (See Item 1)
L Rating At 400 F — Less Than 1 CFM/sq ft	FTH Rating — 0 Hr



1. Wall Assembly — The 1 or 2 hr fire-rated gypsum board/stud wall assembly shall be constructed of the materials and in the manner described in the individual U300, U400, V400 or W400 Series Wall or Partition Design in the UL Fire Resistance Directory and shall include the following construction features:

A. Studs — Wall framing may consist of either wood studs or steel channel studs. Wood studs to consist of nom 2 by 4 in. (51 by 102 mm) lumber spaced 16 in. (406 mm). OC. Steel studs to be min 3-5/8 in. (92 mm) wide and spaced max 24 in. (610 mm) OC.

B. Gypsum Board* — 5/8 in. (16 mm) thick, 4 ft (1.2 m) wide with square or tapered edges. The gypsum board type, thickness, number of layers, fastener type and sheet orientation shall be as specified in the individual Design in the UL Fire Resistance Directory. Max diam of opening is 4 in. (102 mm).

The hourly F and FH Ratings of the firestop system are equal to the hourly fire rating of the wall assembly in which it is installed.

2. Through Penetrants — A max of four nom 1 in. (25 mm) diam (or smaller) flexible aluminum tubing to be installed within the opening. The space between the through penetrants shall be a min of 0 in. (point contact) to a max of 1/4 in. (6 mm). The annular space between the through penetrants and periphery of opening shall be min 0 in. (point contact) to max 1-1/2 in. (38 mm). Tubing to be rigidly supported on both sides of wall assembly.

3. Fill, Void or Cavity Material* — Sealant — Min 5/8 in. (16 mm) thickness of fill material applied within annulus, flush with both surfaces of wall. At the point contact location between through penetrants and gypsum wallboard, a min 3/8 in. (10 mm) diam bead of fill material shall be applied at the gypsum wallboard/through penetrant interface on both surfaces of wall. Additional sealant shall be forced into interstices of through penetrants to max extent possible.

RECTORSEAL — FlameSafe FS1900, FS1901, FS1905, FS1929, Metacaulk 1000, Metacaulk 350i, Biostop 350i or Biostop 500+

* Indicates such products shall bear the UL or cUL Certification Mark for jurisdictions employing the UL or cUL Certification (such as Canada), respectively.