



System No. W-L-1139

July 29, 1998

F Rating — 2 Hr

T Ratings — 0, 1/4 and 2 Hr (See Item 3C)

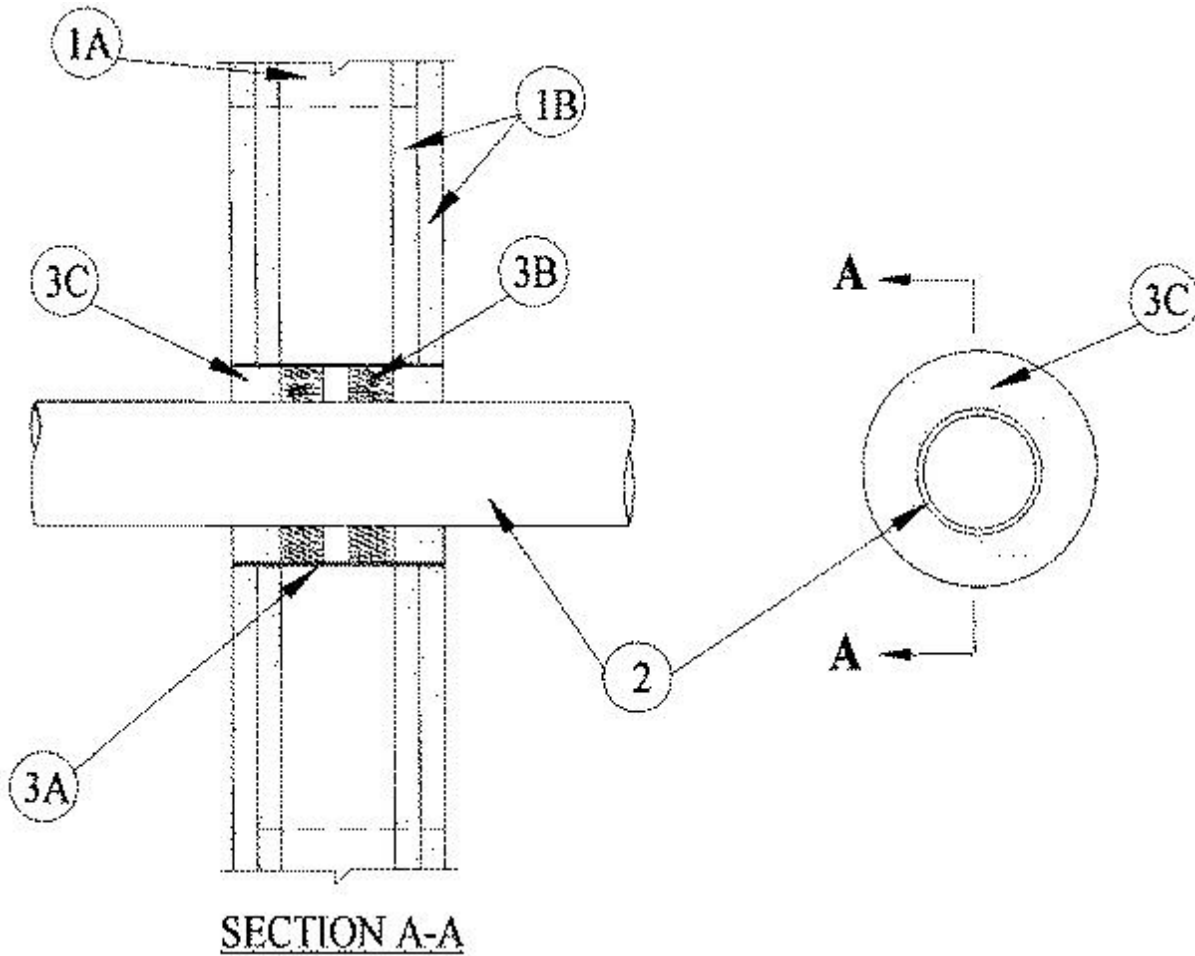

1. **Wall Assembly** — The fire-rated gypsum wallboard/stud wall assembly shall be constructed of the materials and in the manner specified in the individual U300 or U400 Series Wall and Partition Designs in the UL fire Resistance Directory and shall include the following construction features:

A. **Studs** — Wall framing may consist of either wood studs or steel channel studs. Wood studs to consist of nom 2 by 4 in. lumber spaced 16 in. OC. Steel studs to be min 2-1/2 in. wide and spaced max 24 in. OC.

B. **Gypsum Board*** — Two layers of nom 5/8 in. thick gypsum wallboard, as specified in the individual Wall and Partition Design. Max diam of opening is 8 in.

2. **Through-Penetrants** — One metallic pipe, conduit or tubing to be installed either concentrically or eccentrically within the firestop system. Pipe, conduit or tubing to be rigidly supported on both sides of wall assembly. The annular space between pipe, conduit or tubing and periphery of opening shall be as shown in the table below. The following types and sizes of metallic pipes or tubing may be used:

A. **Conduit** — Nom 4 in. diam (or smaller) steel electrical metallic tubing or steel conduit.

B. **Copper Tubing** — Nom 4 in. diam (or smaller) Type L (or heavier) copper tubing.

3. **Firestop System** — The hourly F and T Rating for the firestop systems are dependent upon the type and size of pipe, annular space, fill material thickness and fill material type as described in the table below. When the annular space in the

table shows a range of distances, the penetrating item may be installed either concentrically or eccentrically within the firestop system. The firestop system shall consist of the following:

A. Steel Sleeve or Wire Mesh — No. 8 steel wire mesh having a min 1 in. lap along the longitudinal seam. Length of sleeve to be 1/4 to 1/2 in. less than overall thickness of wall such that, when installed in circular opening, the ends of the sleeve are recessed 1/8 to 1/4 in. from each surface of the wall. Sleeve may also be formed of min 0.034 in. thick (20 MSG) galv sheet steel.

B. Packing Material — Mineral wool batt insulation firmly packed into opening as a permanent form at the thickness shown in the table below. Packing material to be recessed from both surfaces of wall as required to accommodate the required thickness of fill material. As an option to the above, backer rod and/or foamed plastic backer material may be used.

C. Fill, Void or Cavity Material — Caulk* — Applied within the annulus, flush with both surfaces of wall as shown in the table below:

Pipe Type	Diam, In.	Annular Space In.	Min Forming Mtl Depth In.	Min Fill Mtl Depth	F Rating Hr	T Rating Hr
2A	4	3/4 to	1/4	1/4	2	1/4
		3-1/2				
2B	4	3/4 to	1/2	1/2	2	0
		3-1/2				
2A	4	3/4 to	1	1	2	1/4
		3-1/2				

RECTORSEAL — BF-150 Caulk

*Bearing the UL Classification Mark