

System No. W-J-7138

May 08, 2015

ANSI/UL1479 (ASTM E814)	CAN/ULC S115
F Rating — 2 Hr	F Rating — 2 Hr
T Rating — 0 Hr	FT Rating — 0 Hr
	FH Rating — 2 Hr
	FTH Rating — 0 Hr

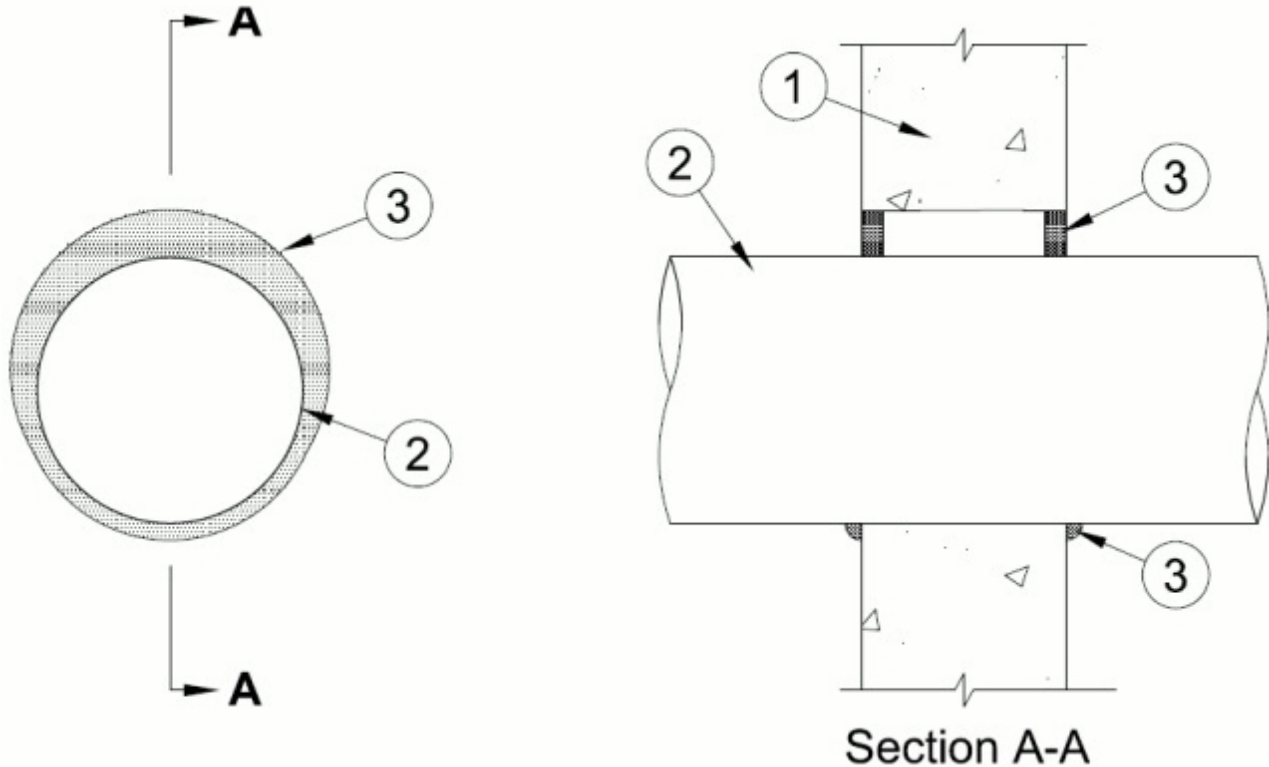

1. **Wall Assembly** — Min 6 in. (152 mm) thick lightweight or normal weight (100-150 pcf or 1600-2400 kg/m³) concrete. Wall may also be constructed of any UL Classified **Concrete Blocks***. Diam of opening to be max 1 in. (25 mm) larger than OD of steel duct (Item 2). Max diam of opening is 11 in. (279 mm).

See **Concrete Blocks** (CAZT) category in the Fire Resistance Directory for names of manufacturers.

2. **Steel Duct** — Nom 10 in. (254 mm) diam (or smaller) No. 28 gauge (or heavier) spiral wound or long seam galv steel duct. The duct shall be constructed and reinforced in accordance with SMACNA construction standards. Annular space between duct and periphery of opening to be min 0 in. (point contact) to max 1 in. (25 mm). Duct to be rigidly supported on both sides of the wall assembly.

3. **Fill, Void or Cavity Material* — Sealant** — Min 1/2 in. (13 mm) thickness of fill material applied within annulus, flush with both surfaces of wall assembly. At point contact location, min 3/8 in. (9.5 mm) diam bead of fill material applied at steel duct/gypsum board interface on both surfaces of wall.

RECTORSEAL — Metacaulk 1200 Caulk Grade, Metacaulk 150+, Metacaulk 1000, Metacaulk 350i, Biostop 750, Biostop BF 150+, Biostop 500+, Biostop 350i, FlameSafe FS1900

* Indicates such products shall bear the UL or cUL Certification Mark for jurisdictions employing the UL or cUL Certification (such as Canada), respectively.