

System No. W-J-5132

September 26, 2005

F Rating — 2 Hr

T Rating — 2 Hr

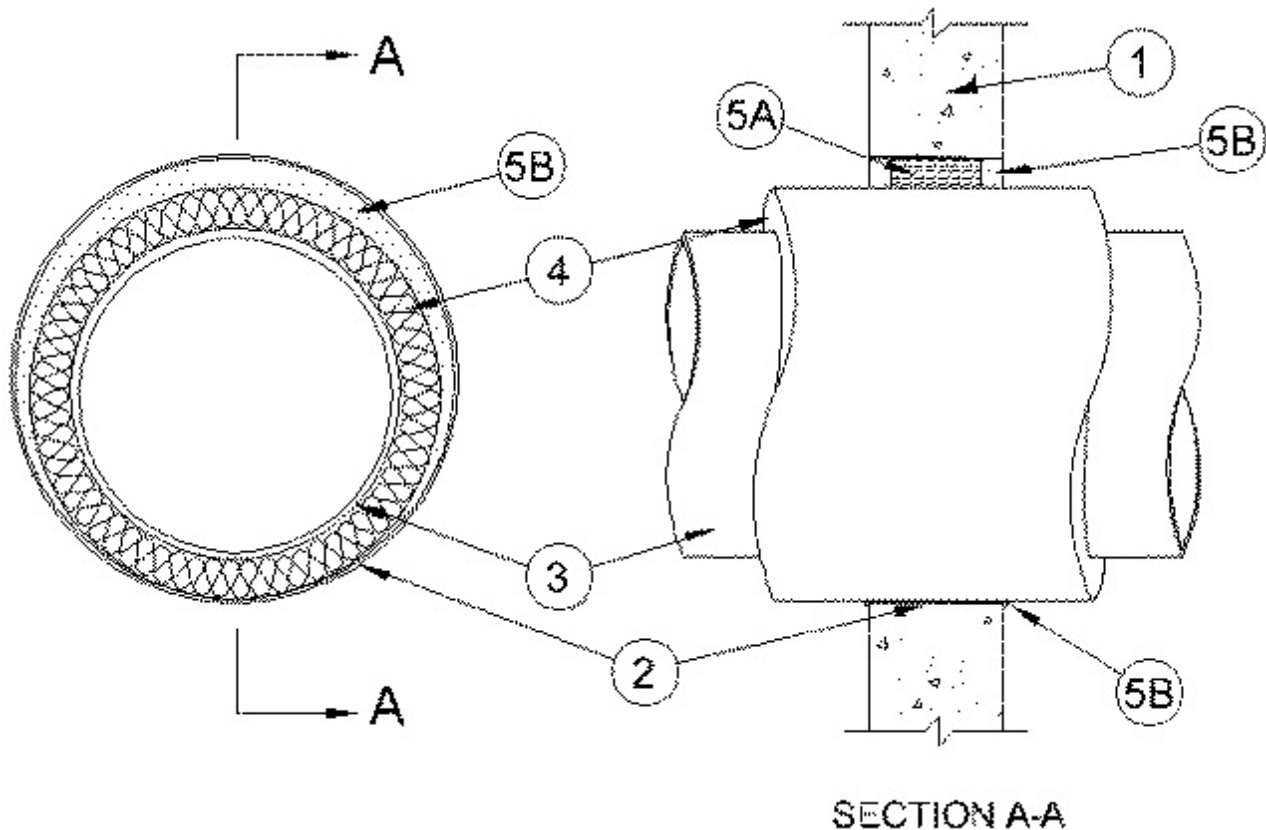

1. **Wall Assembly** — Min 5 in. (127 mm) thick reinforced lightweight or normal weight (100-150 pcf or 1600-2400 kg/m³) concrete. Wall may also be constructed of any UL Classified **Concrete Blocks***. Max diam of opening is 28 in. (711 mm).

See **Concrete Blocks** (CAZT) category in the Fire Resistance Directory for names of manufacturers.

2. **Steel Wire Mesh** — Cylindrical sleeve fabricated from No. 8 steel wire mesh and having a min 1 in. (25 mm) lap along the longitudinal seam. Length of steel wire mesh to be 1/2 in. (13 mm) less than thickness of the wall. Steel wire mesh to be centered and formed to fit periphery of through opening.

3. **Through Penetrants** — One metallic pipe or tubing to be installed either concentrically or eccentrically within the firestop system. Pipe or tubing to be rigidly supported on both sides of wall assembly. The following types and sizes of metallic pipes or tubing may be used:

A. **Steel Pipe** — Nom 20 in. (508 mm) diam (or smaller) Schedule 10 (or heavier) steel pipe.

B. **Iron Pipe** — Nom 20 in. (508 mm) diam (or smaller) cast or ductile iron pipe.

C. **Copper Tubing** — Nom 2 in. (51 mm) diam (or smaller) Type L (or heavier) copper tubing.

D. **Copper Pipe** — Nom 2 in. (51 mm) diam (or smaller) Regular (or heavier) copper pipe.

4. **Pipe Covering*** — Nom 3 in. (76 mm) thick hollow cylindrical heavy density glass fiber units jacketed on the outside with an all service jacket. Longitudinal joints sealed with metal fasteners or factory-applied self-sealing lap tape. Transverse joints secured with metal fasteners or with butt tape supplied with the product. The annular space shall be min 0 in. (point

contact) to max 2 in. (51 mm).

See **Pipe and Equipment Covering — Materials** (BRGU) category in the Building Materials Directory for names of manufacturers. Any pipe covering material meeting the above specifications and bearing the UL Classification Marking with a Flame Spread Index of 25 or less and a Smoke Developed Index of 50 or less may be used.

5. Firestop System — The firestop system shall consist of the following:

A. **Packing Material** — Min 3 in. (76 mm) thickness of min 4 pcf (64 kg/m³) mineral wool batt insulation firmly packed into opening as a permanent form. Packing material to be recessed from both surfaces of wall to accommodate the required thickness of fill material.

B. **Fill, Void or Cavity Material*** — **Caulk** — Min 1 in. (25 mm) thickness of fill material applied within the annulus, flush with both surfaces of wall. At the point contact location between pipe insulation and wall, a min 1/4 in. (6 mm) diam bead of fill material shall be applied at the wall/pipe insulation interface on both surfaces of wall.

RECTORSEAL — Biostop 350i

*Bearing the UL Classification Mark