

## System No. W-J-3089

April 03, 2003

F Rating — 2 Hr

T Rating — 0 Hr

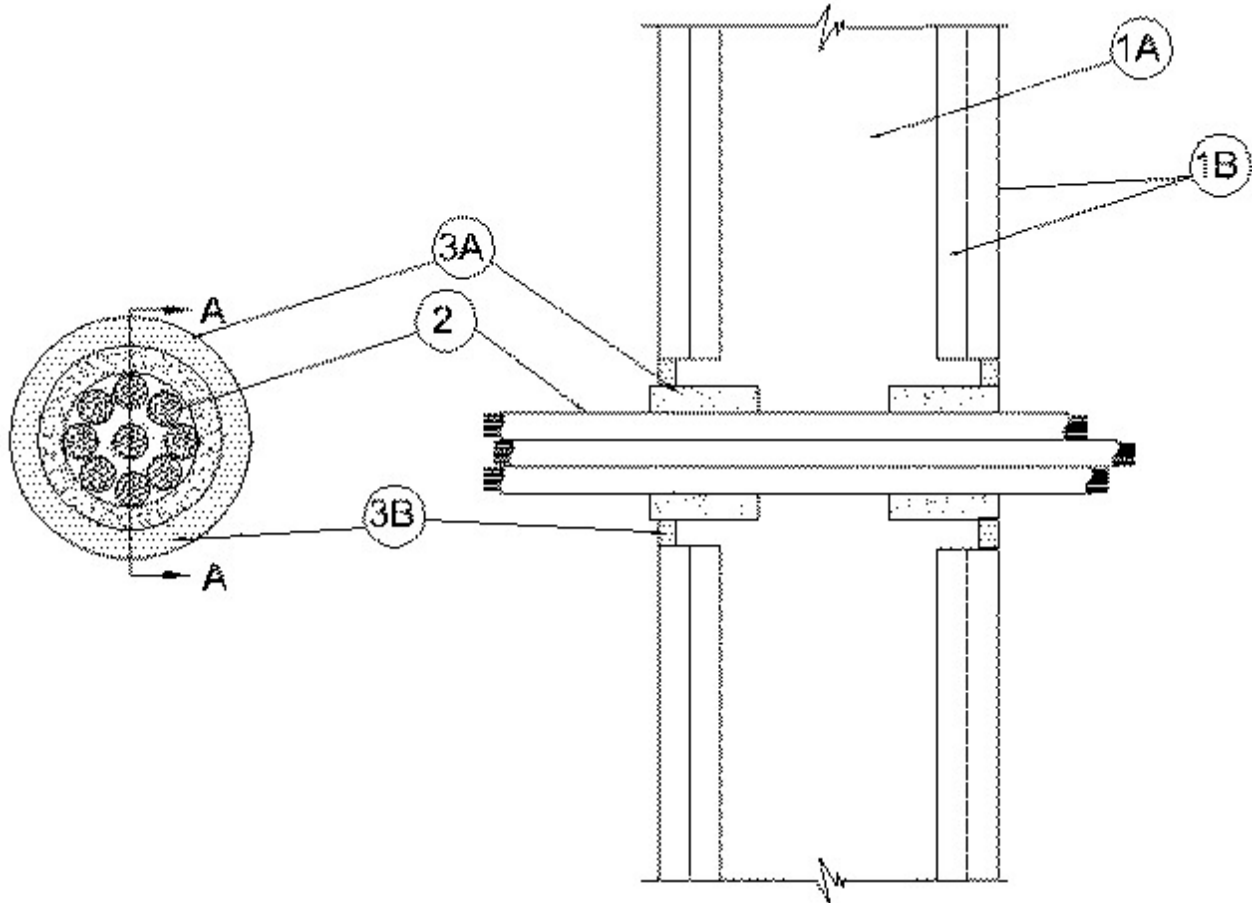

1. **Wall Assembly** — Min 4-1/2 in. thick reinforced lightweight or normal weight (100-150 pcf) concrete. Wall may also be constructed of any UL Classified **Concrete Blocks**\*. Max diam of opening is 3 in.

See **Concrete Blocks** (CAZT) category in the Fire Resistance Directory for names of manufacturers.

2. **Cables** — Max 2 in. diam tight bundle of cables centered in opening and rigidly supported on both sides of wall assembly. Annular space between cable bundle and wall opening is max 1/2 in. Any combination of the following types and sizes of copper conductor cables may be used:

- A. Max 4 pair, No. 24 AWG telephone cable with polyvinyl chloride (PVC) insulation and jacket materials.
- B. Max 25 pair, No. 24 AWG telephone cable with polyvinyl chloride (PVC) insulation and jacket materials.
- C. Max 2/C No. 12 AWG MC (BX) cable with copper conductors and polyvinyl chloride (PVC) insulation.
- D. Max 4 pair, 24 AWG computer network cable with polyvinyl chloride (PVC) insulation and jacket materials.

E. Max 2 cond., 14 AWG alarm coaxial cable with polyvinyl chloride (PVC) insulation and jacket materials.

F. Max 3/C No. 12 AWG (or smaller) nonmetallic sheathed (Romex) cable with copper conductors, PVC insulation and jacket.

G. Max 4/C No. 18 AWG bimetal conductors Type CL-2 (UL) Listed thermostat cable.

3. **Firestop System** — The firestop system shall consist of the following:

A. **Fill, Void or Cavity Material\* - Wrap Strip** — One layer of nom 1/4 in. thick intumescent elastomeric material supplied in nom 2 in. wide strips. Wrap strip tightly wrapped around cable bundle with seam butted and secured with electrical tape. Wrap strip slid into annular space such that approx 1/4 in. of the wrap strip protrudes from the wall surface on each side of the wall assembly.

**RECTORSEAL** — Biostop Wrap Strip

B. **Fill, Void or Cavity Materials\* - Caulk** — Min 1/4 in. thickness of caulk applied to the annular space between wrap strip and periphery of opening on each side of wall assembly. Caulk to be forced into the interstices of the cable bundle to the max extent possible within the confines of the wrap strip on each side of the wall assembly.

**RECTORSEAL** — Biostop 500+

\*Bearing the UL Classification Mark