

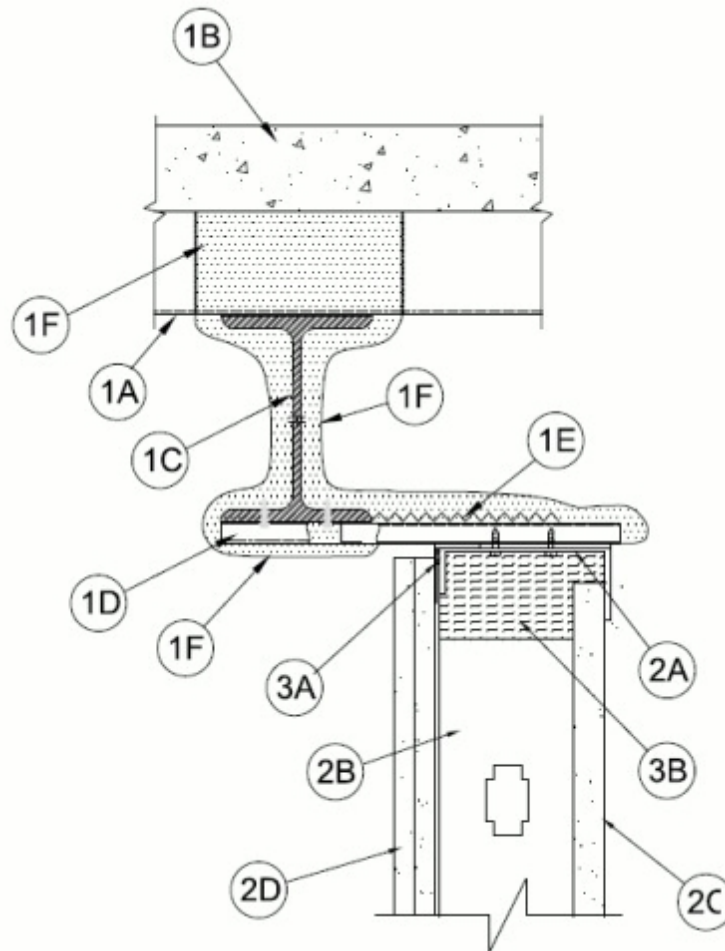

System No. HW-D-0722

October 28, 2013

| ANSI/UL2079 | CAN/ULC S115 |
|---|---|
| Assembly Ratings — 1 and 2 Hr (See Items 1 and 2) | F Ratings — 1 and 2 Hr (See Items 1 and 2) |
| Maximum Joint Width - 3/8 in. | FT Ratings — 1 and 2 Hr (See Items 1 and 2) |
| Class II or III Movement Capabilities - 100% Compression or Extension | FH Ratings — 1 and 2 Hr (See Items 1 and 2) |
| L Rating At Ambient — Less Than 1 CFM/Lin ft | FTH Ratings — 1 and 2 Hr (See Items 1 and 2) |
| L Rating At 400 F — Less Than 1 CFM/Lin ft | Maximum Joint Width - 3/8 In. |
| | Class II or III Movement Capabilities - 100% Compression or Extension |
| | L Rating At Ambient — Less Than 1 CFM/Lin ft |
| | L Rating At 400 F — Less Than 1 CFM/Lin ft |



1. **Floor Assembly** — The fire-rated fluted steel deck/concrete floor assembly shall be constructed of the materials and in the manner described in the individual D700 or D900 Series Floor-Ceiling Design in the UL Fire Resistance Directory and shall include the following construction features:

A. **Steel Floor And Form Units*** — Max 3 in. (76 mm) deep galv steel fluted floor units.

B. **Concrete** — Min 2-1/2 in. (64 mm) thick reinforced lightweight or normal weight (100-150 pcf

or 1600-2400 kg/m³) concrete, as measured from the top plane of the floor units.

C. Structural Steel Support — Steel beam, as specified in the individual D700 or D900 Series Floor-Ceiling Design, used to support steel floor units. Steel beam parallel with wall assembly and 8 in. (203 mm) max from wall assembly.

D. Steel Attachment Clips — Z-shaped bars or channels, located to span from steel beam to min 1 in. (25 mm) beyond face of wall and spaced max 16 in. (406 mm) on center. Z-shaped bars are nom 1-1/2 to 2 in. (38 to 51 mm) deep and formed from min 20 gauge painted or galvanized steel. Channels are nom 1-1/2 in. (38 mm) or 2 in. (51 mm) deep and formed from min 20 gauge painted or galvanized steel. Each bar or channel welded to steel beam and welded, bolted or screwed to ceiling runner of wall. Each bar or channel shall be fully covered with spray applied fire resistive material (Item 1F) to the minimum thickness of material required on the flanges of the steel beam.

E. Steel Lath — Nom 3/8 in. (10 mm) diamond mesh expanded steel rib lath having a nom weight of 3.4 lb/yd² (1.8 kg/m²) shall be installed over and attached to the steel attachment clip bars or channels (Item 1D) to completely cover the exposed area from the flange tip of the steel beam to the end of the bar/channel framing extending beyond the wall surface. The lath shall be secured with steel fasteners or tie wire and shall be fully covered with spray applied fire resistive material (Item 1F).

F. Spray-Applied Fire Resistive Material* — After installation of steel attachment clip and steel lath (Items 1D and 1E), steel floor units and structural steel support to be sprayed with the min thickness of material specified in the individual D700 or D900 Series Design. The flutes of the steel floor units are to be filled with material across the entire top flange of the steel beam. Each bar or channel attachment clip member (Item 1D) shall be fully covered with spray applied fire resistive material to the minimum thickness of material required on the flanges of the steel beam. The thickness of material applied to the expanded steel lath shall be sufficient to completely fill the spaces between the bar/channel attachment clip above the wall. Additional material shall be applied to the web of the steel beam on each side of the wall. The min total thickness of material applied to each side of the steel beam web shall be 13/16 in. (21 mm) for 1 hr fire rated assemblies and 1 3/8 in. (35 mm) for 2 hr fire rated assemblies. For D700 Series Designs, all surfaces of the steel floor units to be sprayed with the thickness of material specified in the individual D700 Series Design. For D900 Series Designs structural steel supports, steel attachment clip and steel lath only to be sprayed in accordance with the specifications in the individual D900 Series Design.

ISOLATEK INTERNATIONAL — Type 300 or Type II

W R GRACE & CO - CONN — Type MK-6/HY, MK-6/HYES, MK-65 and RG

The hourly fire rating of the floor assembly shall be equal to or greater than the hourly fire rating of the wall assembly.

1A. Roof Assembly — (Not Shown) — As an alternate to the floor assembly, a fire-rated fluted steel deck roof assembly may be used. The roof assembly shall be constructed of the materials and in the manner described in the individual P900 or P700 Series Roof-Ceiling Design in the UL Fire Resistance Directory. The roof assembly shall include the following construction features:

A. Steel Roof Deck — Max 3 in. (76 mm) deep galv steel fluted roof deck.

B. Roof Insulation — For P900 Series Designs, min 2-1/4 in. (57 mm) thick poured insulating concrete, as measured from the top roof deck. For P700 Series Designs, roof insulation shall be as specified in the individual design.

C. Structural Steel Support — Steel beam, as specified in the individual P700 or P900 Series Floor-Ceiling Design, used to support steel floor units. Steel beam parallel with wall assembly and 8 in. (203 mm) max from wall assembly.

D. Steel Attachment Clips — Z-shaped bars or channels, located to span from steel beam to min 1 in. (25 mm) beyond face of wall and spaced max 16 in. (406 mm) on center. Z-shaped bars are nom 1-1/2 to 2 in. (38 to 51 mm) deep and formed from min 20 gauge painted or galvanized steel. Channels are nom 1-1/2 in. (38 mm) or 2 in. (51 mm) deep and formed from min 20 gauge painted or galvanized steel. Each bar or channel welded to steel beam and welded, bolted or screwed to ceiling runner of wall. Each bar or channel shall be fully covered with spray applied fire resistive material to the minimum thickness of material required on the flanges of the steel beam.

E. Steel Lath — Nom 3/8 in. (10 mm) diamond mesh expanded steel rib lath having a nominal weight of 3.4 lb/yd² (1.8 kg/m²) shall be installed over and attached to the steel attachment clip bars or channels (Item 1AD) to completely cover the exposed area from the flange tip of the steel beam to the end of the bar/channel framing extending beyond the wall surface. The lath shall be secured with steel fasteners or tie wire and shall be fully covered with spray applied fire resistive material (Item 1AF).

F. Spray-Applied Fire Resistive Material* — After installation of steel attachment clip and steel lath (Items 1AD and 1AE) surfaces of the roof deck to be sprayed with the thickness of material specified in the individual P700 Series Design. For P900 Series Designs structural steel supports, steel attachment clip and steel lath only to be sprayed in accordance with the specifications in the individual P900 Series Design. The flutes of the steel roof deck are to be filled with material across the entire top flange of the steel beam. Each bar or channel attachment clips (Item 1AD) shall be fully covered with spray applied fire resistive material to the minimum thickness of material required on the flanges of the steel beam. The thickness of material applied to the expanded steel lath shall be sufficient to completely fill the spaces between the bar/channel attachment clip above the wall. Additional material shall be applied to the web of the steel beam on each side of the wall. The min total thickness of material applied to each side of the steel beam web shall be 13/16 in. (21 mm) for 1 hr fire rated assemblies and 1-3/8 in. (35 mm) for 2 hr fire rated assemblies.

ISOLATEK INTERNATIONAL — Type 300 or Type II

W R GRACE & CO - CONN — Type MK-6/HY, MK-6/HYES, MK-65 and RG

The hourly fire rating of the roof assembly shall be equal or greater than the hourly fire rating of the wall assembly.

2. Shaft Wall Assembly — The 1 or 2 hr fire rated gypsum board/stud wall assembly shall be constructed of the materials and in the manner described in the individual U400, V400 or W400 Series Wall and Partition Design in the UL Fire Resistance Directory and shall include the following construction features:

A. Floor and Ceiling Runners — "J"-shaped runner, min 4 in. (102 mm) wide with unequal legs of min 1 in. (25 mm) and min 2 in. (51 mm), fabricated from min 24 MSG galv steel. Ceiling runner installed offset below and parallel to steel beam with short leg toward finished side of wall. Ceiling runner to be attached to steel attachment clips (Item 1D) with steel fasteners spaced a max 16 in. (406 mm) OC with two fasteners into each clip. As an alternate to the "J"-shaped runner, a min 4 in. (102 mm) wide by 1 or 1-1/4 in. (25 or 32 mm) deep channel formed from min 25 MSG galv steel may be used for the floor runner.

B. Studs — "C-T", "I", or "C-H" shaped steel studs to be min 4 in. (102 mm) wide and formed of min 25 ga galv steel. Studs cut 5/8 to 3/4 in. (16 to 19 mm) less in length than assembly height with bottom nesting in floor runner. Studs spaced max 24 in. (610 mm) OC.

C. Gypsum Board* — 1 in. (25 mm) thick by max 24 in. (610 mm) wide gypsum board liner panels. Panels cut max 1 in. (25 mm) less in length than floor to wall assembly height. Vertical edges inserted into "T" shaped section of "C-T" studs, into holding tabs of "I" studs or into "H"-shaped section of "C-H" studs.

D. Gypsum Board* — Gypsum board 5/8 in. (16 mm) thick, applied on finished side of wall as specified in the individual Wall and Partition Design. The boards cut a max 3/8 in. (9.5 mm) less in length than the floor to wall assembly height. The screws attaching the gypsum board layer(s) to the "C-T", "I", or "C-H" studs shall be located 1 to 1-1/2 in. (25 to 38 mm) down from ceiling runner at time of installation. No gypsum board attachment screws shall be driven into the ceiling runner.

The hourly fire rating and the F, FT, FH and FTH ratings of the joint system are equal to the hourly fire rating of the wall.

3. Joint System — Max separation between bottom plane of spray-applied fire resistive material on the steel attachment clips (Item 1D) and the top of the gypsum board on finished side of wall is 1 in. (25 mm). The joint system is designed to accommodate a max 100 percent compression or extension from its installed width. The joint system shall consist of the following:

A. Fill, Void or Cavity Material* — Min 25 ga composite steel angle with one 5/8 in. (16 mm) leg and one 1-1/2 in (38 mm) leg with an intumescent strip affixed along the inside 1-1/2 in (38 mm) leg. The 5/8 in. leg of steel angle is friction fit between the top web of the ceiling runner and the steel attachment clips. Steel angle is required on finished side of wall only.

RECTORSEAL — Track Safe

B. Forming Material* — Min 3 in. (76 mm) thickness of min 4 pcf (64 kg/m³) mineral wool batt insulation cut to width of stud, compressed min 25 percent in width and friction fit into ceiling runner between leg of track and gypsum liner board.

See **Forming Material** (XHKU) category in the Fire Resistance Directory for names of manufacturers.

*Bearing the UL Classification Mark