

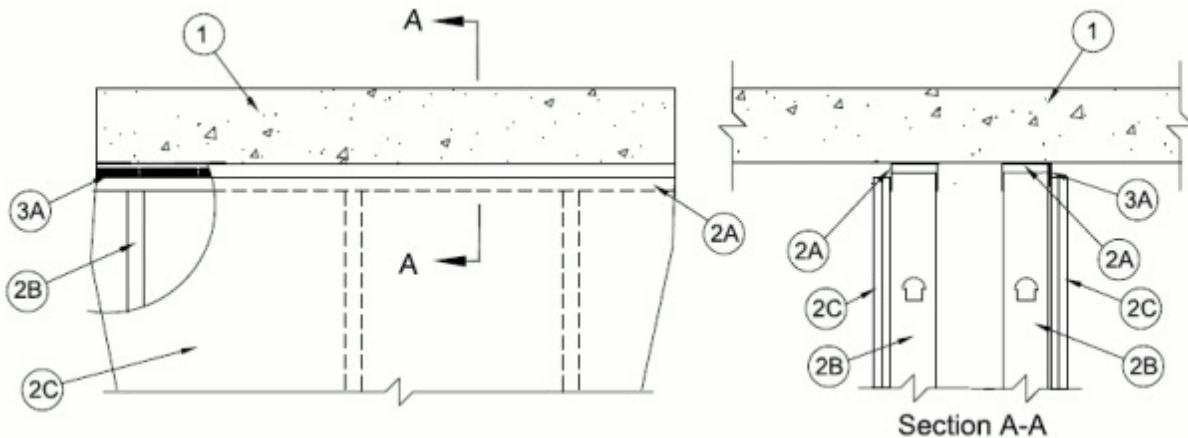

System No. HW-D-0717

October 24, 2013

ANSI/UL2079	CAN/ULC S115
Assembly Ratings — 1 and 2 Hr (See Item 2)	F Ratings — 1 and 2 Hr (See Item 2)
Nominal Joint Width - 1/2 in.	FT Ratings — 1 and 2 Hr (See Item 2)
Class II or III Movement Capabilities — 100% Compression or Extension for 3/8 In. Joint; 100% Compression or 0% Extension for 3/4 In. Joint	FH Ratings — 1 and 2 Hr (See Item 2)
L Rating at Ambient — Less than 1 CFM/Lin Ft	FTH Ratings — 1 and 2 Hr (See Item 2)
L Rating at 400°F — Less than 1 CFM/Lin Ft	Nominal Joint Width - 1/2 in.
	Class II or III Movement Capabilities — 100% Compression or Extension
	L Rating at Ambient — Less than 1 CFM/Lin Ft
	L Rating at 400°F — Less than 1 CFM/Lin Ft



1. Floor or Roof Assembly — Min 4-1/2 in. (114 mm) thick reinforced lightweight or normal weight (100-150 pcf or 1600-2400 kg/m³) structural concrete.

2. Chase Wall Assembly — The 1 or 2 hr fire rated gypsum board/stud chase (double stud) wall assembly shall be constructed of the materials and in the manner described in the individual U400, V400 or W400 Series Wall and Partition Design in the UL Fire Resistance Directory and shall include the following construction features:

A. Steel Floor and Ceiling Runners — Channel shaped ceiling runner with width to accommodate studs, legs of min 2 in. (51 mm), and fabricated from min 24 MSG galv steel. Floor runners of wall assembly shall consist of min No. 25 ga galv steel channels sized to accommodate the steel studs. Floor runner to be provided with min 1-1/4 in. (32mm) flanges. Ceiling runner to be attached to concrete floor with steel masonry fasteners spaced a max of 24 in. (610 mm) O.C.

B. Studs — Steel studs to be min 3-1/2 in. (89 mm) wide and formed of min 25 ga galv steel. Studs cut 3/4 to 1 in. (19 to 25 mm) less in length than assembly height with bottom nesting in and secured to floor runner. Steel studs nested in ceiling runner without attachment. Studs spaced max 24 in. (610 mm) OC.

C. Gypsum Board* — Gypsum board 1/2 or 5/8 in. (13 or 16 mm) thick, applied on both sides of wall as specified in the individual Wall and Partition Design except that a max 1/2 in. (13 mm) gap shall be maintained between the top of the gypsum board and the bottom of the floor assembly. The screws attaching the gypsum board to the studs along the top of the wall shall

be located 3 to 3-1/2 in. (76 to 89 mm) down from floor at time of installation. No gypsum board attachment screws shall be driven into the ceiling runner.

The hourly assembly rating and F, FT, FH and FTH ratings of the joint system is equal to the hourly fire rating of the wall.

3. Joint System — Max separation between bottom of floor and top of gypsum board (at time of installation) is 1/2 in. (13 mm). The joint system is designed to accommodate a max 100 percent compression or extension from its installed width. The joint system shall consist of the following:

A. Fill, Void or Cavity Material* — Min 25 ga composite steel angle with one 5/8 in. (16 mm) leg and one 1-1/2 in (38 mm) leg with an intumescent strip affixed along the inside 1-1/2 in (38 mm) leg. The 5/8 in. leg of steel angle is friction fit between the top web of one ceiling runner and the concrete floor. Steel angle is required on one side of wall only (either side).

RECTORSEAL — Track Safe

*Bearing the UL Classification Mark