

System No. HW-D-0713

October 24, 2013

ANSI/UL2079	CAN/ULC S115
Assembly Rating — 1 and 2 Hr (See Item 2)	F Ratings — 1 and 2 Hr (See Item 2)
Nominal Joint Width - 1/2 in.	FT Ratings — 1 and 2 Hr (See Item 2)
Class II or III Movement Capabilities — 100% Compression or Extension	FH Ratings — 1 and 2 Hr (See Item 2)
L Rating at Ambient — Less than 1 CFM/Lin Ft	FTH Ratings — 1 and 2 Hr (See Item 2)
L Rating at 400°F — Less than 1 CFM/Lin Ft	Nominal Joint Width - 1/2 in.
	Class II or III Movement Capabilities — 100% Compression or Extension for 3/8 In. Joint; 100% Compression or 0% Extension for 3/4 In. Joint
	L Rating at Ambient — Less than 1 CFM/Lin Ft
	L Rating at 400°F — Less than 1 CFM/Lin Ft

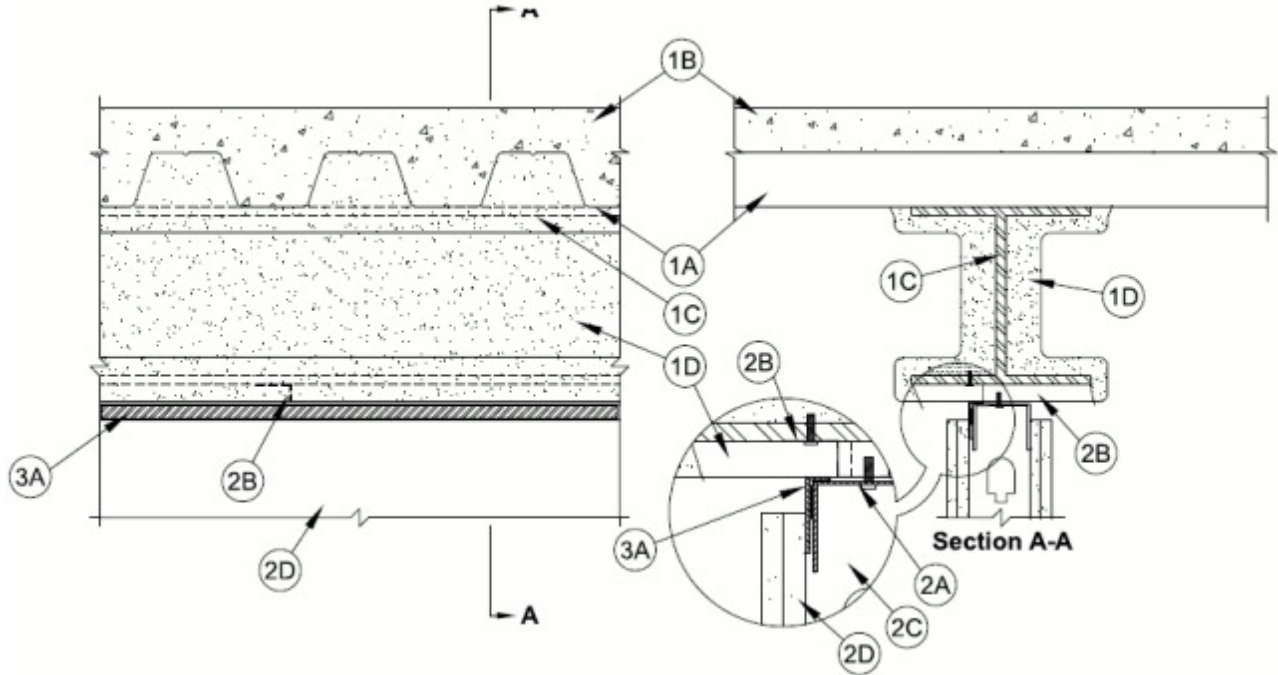

1. **Floor Assembly** — The fire-rated fluted steel deck/concrete floor assembly shall be constructed of the materials and in the manner described in the individual D700 or D900 Series Floor-Ceiling Design in the UL Fire Resistance Directory and shall include the following construction features:

A. **Steel Floor And Form Units*** — Max 3 in. (76 mm) deep galv steel fluted floor units.

B. **Concrete** — Min 2-1/2 in. (64 mm) thick reinforced concrete, as measured from the top plane of the floor units.

C. **Structural Steel Support** — Steel beam, as specified in the individual D700 or D900 Series Floor-Ceiling Design, used to support steel floor units. Steel Beam centered over and parallel with wall assembly.

D. **Spray-Applied Fire Resistive Material*** — After installation of the steel attachment clips (Item 2B), steel floor units, and ceiling runner (Item 3), all surfaces of the steel floor units and

structural steel support to be sprayed with the thickness of material specified in the individual D700 or D900 Series Floor-Ceiling Design. The flutes of the steel floor units are to be filled with material across the entire top flange of the steel beam. The areas between the bottom flange of the structural support and top of the ceiling runner are to be filled entirely with material. Additional material shall be applied to the web of the steel beam on each side of the wall. The thickness of material applied to each side of the steel beam web shall be 2 in. (51 mm).

ISOLATEK INTERNATIONAL — Type 300

W R GRACE & CO - CONN — Type MK-6/HY

1A. **Roof Assembly** — (Not Shown) - As an alternate to the floor assembly, a fire rated fluted steel deck roof assembly may be used. The roof shall be constructed of the materials and in the manner described in the individual P700 or P900-Series Roof-Ceiling designs in the UL Fire Resistance Directory. The hourly rating of the roof assembly shall be equal to or greater than the hourly rating of the wall assembly. The roof assembly shall include the following construction features:

A. **Steel Roof Deck** — Max 3 in. (76 mm) deep galv steel fluted roof deck.

B. **Roof Insulation** — Roof insulation to consist of min 2-1/4 in. (57 mm) thick poured insulating concrete, as measured from the top plane of the roof deck.

C. **Structural Steel Support** — Steel Beam, as specified in the individual P700 or P900 Series Floor-Ceiling Design, used to support steel floor units. Steel Beam centered over and parallel with wall assembly.

D. **Spray-Applied Fire Resistive Material*** — After installation of the steel attachment clips (Item 2B), steel floor units, and ceiling runner (Item 3), all surfaces of the steel floor units and structural steel support to be sprayed with the thickness of material specified in the individual P700 or P900 Series Floor-Ceiling Design. The flutes of the steel floor units are to be filled with material across the entire top flange of the steel beam. The areas between the bottom flange of the structural support and top of the ceiling runner are to be filled entirely with material. Additional material shall be applied to the web of the steel beam on each side of the wall. The thickness of material applied to each side of the steel beam web shall be 2 in. (51 mm).

ISOLATEK INTERNATIONAL — Type 300

W R GRACE & CO - CONN — Type MK-6/HY

2. **Wall Assembly** — The 1 or 2 hr fire rated gypsum board/stud wall assembly shall be constructed of the materials and in the manner described in the individual U400, V400 or W400 Series Wall and Partition Design in the UL Fire Resistance Directory and shall include the following construction features:

A. **Steel Floor and Ceiling Runners** — Channel shaped runner with width to accommodate studs, legs of min 2 in. (51 mm), and fabricated from min 24 MSG galv steel. Ceiling runner installed below and parallel to steel beam. Floor runners of wall assembly shall consist of min No. 25 ga galv steel channels sized to accommodate the steel studs. Floor runner to be provided with min 1-1/4 in. (32mm) flanges. Ceiling runner to be attached to steel attachment clips with steel fasteners spaced a max of 16 in. (406 mm) O.C. Floor runner to be attached to floor with steel fasteners spaced a max of 24 in. (610 mm) O.C.

B. **Steel Attachment Clips** — Z-shaped clips formed from 1 in. (25 mm) wide strips of min 20 ga galv steel. Clips sized to extend through the thickness of the spray-applied fire resistive material on the bottom flange of the steel beam with 1-1/2 in. (38 mm) long upper and lower legs. Legs of clips fastened to bottom of beam (prior to application of spray-applied fire-resistive materials) and top of ceiling runner with steel fasteners or welds. Clips spaced max 16 in. (406 mm) OC.

C. **Studs** — Steel studs to be min 3-5/8 in. (92 mm) wide. Studs cut 3/4 to 1 in. (19 to 25 mm) less in length than assembly height with bottom nesting in and secured to floor runner. Steel studs nested in ceiling runner without attachment. Studs spaced max 24 in. (610 mm) OC.

D. **Gypsum Board*** — Gypsum board 5/8 in. (16 mm) thick, applied on both sides of wall as specified in the individual Wall and Partition Design except that a max 1/2 in. (13 mm) gap shall

be maintained between the top of the gypsum board and the bottom of the spray applied fire resistive material on steel beam. The screws attaching the gypsum board to the studs along the top of the wall shall be located 3 to 3-1/2 in. (76 to 89 mm) down from spray applied fire resistive material on beam at time of installation. No gypsum board attachment screws shall be driven into the ceiling runner.

The hourly fire rating and the F, FT, FH and FTH ratings of the joint system are equal to the hourly fire rating of the wall.

3. Joint System — Max separation between spray applied material on beam and top of gypsum board (at time of installation) is 1/2 in. (13 mm). The joint system is designed to accommodate a max 100 percent compression or extension from its installed width. The joint system shall consist of the following:

A. Fill, Void or Cavity Material* — Min 25 ga composite steel angle with one 5/8 in. (16 mm) leg and one 1-1/2 in (38 mm) leg with an intumescent strip affixed along the inside 1-1/2 in (38 mm) leg. The 5/8 in. leg of steel angle is friction fit between the top web of the ceiling runner and the spray applied fire resistive material on steel beam, on one side of wall.

RECTORSEAL — Track Safe

*Bearing the UL Classification Mark