



System No. HW-D-0299

September 04, 2015

Assembly Ratings — 1 and 2 Hr (See Item 2)

Nominal Joint Width — 1 and 2 In. (See Item 3)

Class II Movement Capabilities — 25% Compression or Extension

L Rating At Ambient - Less Than 1 CFM/Lin Ft

L Rating At 400 F - Less Than 1 CFM/Lin Ft

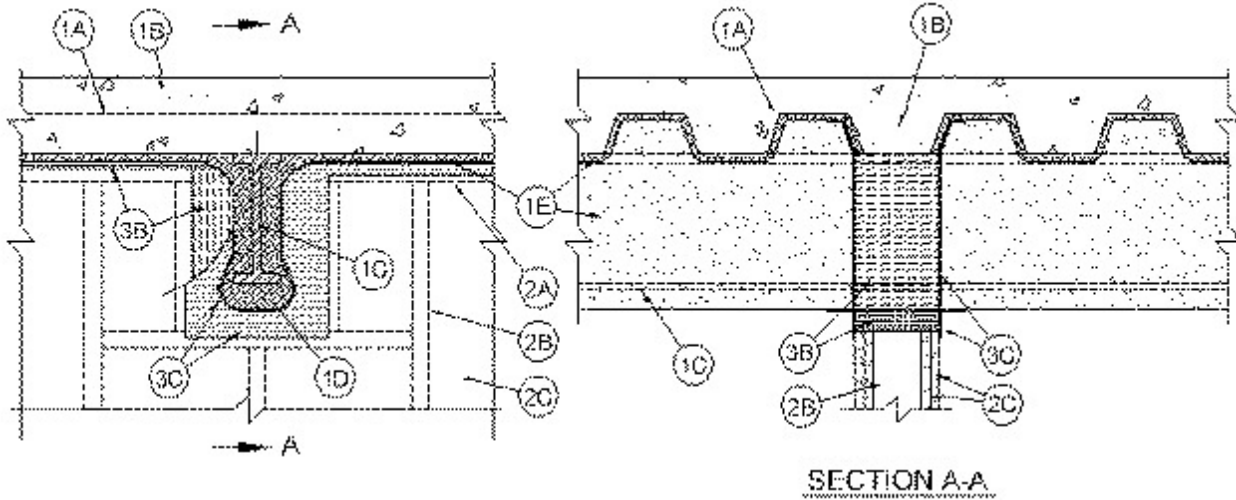

1. Floor Assembly — The fire-rated fluted steel deck/concrete floor assembly shall be constructed of the materials and in the manner described in the individual D900 or D700 Series Floor-Ceiling Design in the UL Fire Resistance Directory and shall include the following construction features:

A. Steel Floor and Floor Units* — Max 3 in. (76 mm) deep galv steel fluted floor units.

B. Concrete — Min 2-1/2 in. (64 mm) thick reinforced concrete, as measured from the top plane of the floor units.

C. Structural Steel Support — (Optional) - Steel beam or open-web steel joist, as specified in the individual D700 Series Floor-Ceiling Design, used to support steel floor units. Structural steel support oriented perpendicular to wall assembly. Where open-web steel joists pass through the fire rated wall, 3/8 in. (10 mm) diamond mesh expanded steel lath having a nom weight of 1.7 to 3.4 lb per sq yd (0.92-1.84 kg/m²) shall be secured to one side of each joist with steel tie wire and the lath shall be fully covered with spray-applied fire resistive material with no min thickness requirement.

D. Spray-Applied Fire Resistive Material* — After installation of the ceiling runner (Item 2A) or deflection channel (Item 3A, if used), steel floor units and structural steel supports to be sprayed in accordance with the specifications in the individual D700 Series Design. For D900 Series Designs structural steel supports only to be sprayed in accordance with the specifications in the individual D900 Series Design.

ISOLATEK INTERNATIONAL — Type 300

W R GRACE & CO - CONN — Type MK-6/HY, MK-6/HY ES, MK-6S and RG

1A. Roof Assembly (Not Shown) — As an alternate to the floor assembly, a fire-rated fluted steel deck roof assembly may be used. The roof assembly shall be constructed of the materials and in the manner described in the individual P700 or P900 Series Roof-Ceiling Design in the UL Fire Resistance Directory. The hourly rating of the roof assembly shall be equal to or greater than the hourly rating of the wall assembly. The roof assembly shall include the following construction details:

A. Steel Roof Deck — Max 3 in. (76 mm) deep galv steel fluted roof deck.

B. Roof Insulation — For P900 Series Designs, min 2-1/4 in. (57 mm) thick poured insulating concrete, as measured from the top plane of the roof deck. For P700 Series Designs, as specified in the individual P700 Series Design.

C. Spray - Applied Fire Resistive Materials* — Prior to the installation of the Forming Material and Fill, Void or Cavity Material (Items 3B and 3C, respectively), the steel roof deck shall be sprayed with the thickness of material specified in the individual P700 Series Design. For P900 Series Designs structural steel supports only to be sprayed in accordance with the specifications in the individual P900 Series Design.

ISOLATEK INTERNATIONAL — Type 300

W R GRACE & CO - CONN — Type MK-6/HY, MK-6/HY ES, MK-6S and RG

2. Wall Assembly — The 1 or 2 hr fire-rated gypsum board/stud wall assembly shall be constructed of the materials and in the manner described in the individual U400 or V400 Series Wall and Partition Design in the UL Fire Resistance Directory and shall include the following construction features:

A. Steel Floor and Ceiling Runners — Floor and ceiling runners of wall assembly shall consist of galv steel channels sized to accommodate steel studs (Item 2B). Ceiling runner to be provided with min 2 in. (51 mm) to max 3 in. (76 mm) flanges. When deflection channel (Item 3A) is used, the ceiling runner is to nest within the deflection channel with a 1/2 in. (13 mm) to 1 in. (25 mm) gap maintained between the top of the ceiling runner and the top of the deflection channel. When deflection channel is not used, ceiling runner to be provided with min 2 in. (51 mm) flanges and secured to steel floor units (Item 1A) with steel fasteners or welds spaced max 24 in. (610 mm) OC. Ceiling runner to be centered beneath and parallel with valley of steel floor unit or roof deck. A clearance of 1 in. (25 mm) shall be maintained between the end of the ceiling runner or deflection channel and the spray applied fire resistive material on the structural steel support members.

A1. Light Gauge Framing* - Slotted Ceiling Runner — As an alternate to the ceiling runner in Item 2A, slotted ceiling runner to consist of galv steel channel with slotted flanges sized to accommodate steel studs (Item 2B). Slotted ceiling runner installed parallel to direction of fluted steel floor units and secured to valleys with steel fasteners spaced max 24 in. (610 mm) OC. When slotted ceiling runner is used, deflection channel (Item 3A) shall not be used.

BRADY CONSTRUCTION INNOVATIONS INC, DBA SLIPTRACK SYSTEMS — SLP-TRK

MARINO/WARE, DIV OF WARE INDUSTRIES INC — Type SLT

A2. Light Gauge Framing* - Clipped Ceiling Runner — As an alternate to the ceiling runner in Items 2A and 2A1, clipped runner to consist of galv steel channel with clips preformed in track flanges which positively engage the inside flange of the steel studs (Item 2B). Track sized to accommodate steel studs (Item 2B). Track flanges to be min 2-1/2 in. (64 mm). Clipped ceiling runner installed parallel to direction of fluted steel floor units and secured to valleys with steel fasteners spaced max 24 in. (610 mm) OC. When clipped ceiling runner is used, deflection channel (Item 3A) shall not be used.

TOTAL STEEL SOLUTIONS L L C — Snap Trak

A3. Light Gauge Framing* - Vertical Deflection Ceiling Runner — As an alternate to the ceiling runner in Items 2A, 2A1 or 2A2, vertical deflection ceiling runner to consist of galv steel channel with slotted vertical deflection clips mechanically fastened within runner. Slotted clips, provided with step bushings, for permanent fastening of steel studs. Vertical deflection ceiling

runner installed parallel to direction of fluted steel floor or roof deck and secured to valleys with steel fasteners spaced max 24 in. (610 mm) OC. When slotted ceiling runner is used, deflection channel (Item 3A) shall not be used.

THE STEEL NETWORK INC — VertiTrack VTD250, VTD362, VTD400, VTD600 and VTD800

B. Studs — Steel studs to be min 3-1/2 in. (89 mm) wide. Studs cut 1/2 in. (13 mm) to 3/4 in. (19 mm) less in length than assembly height with bottom nesting in and secured to floor runner. When deflection channel (Item 3A) is used, steel studs attached to ceiling runner (Item 2A) with sheet metal screws located 1/2 in. (13 mm) below the bottom of the deflection channel. When deflection channel is not used, studs to nest in ceiling runner without attachment. When slotted ceiling runner (Item 2A1) is used, steel studs secured to slotted ceiling runner with No. 8 by 1/2 in. (13 mm) long wafer head steel screws at midheight of slot on each side of wall. When vertical deflection ceiling runner (Item 2A3) is used, steel studs secured to slotted vertical deflection clips, through bushings, with steel screws at midheight of each slot. A framed opening shall be constructed around each structural steel support member. A min clearance of 1 in. (25 mm) to a max clearance of 3 in. (76 mm) shall be maintained between the framing and the spray applied fire resistive material on the two sides of the structural support member. The clearance between the framing and the spray applied fire resistive material on the bottom of the structural steel support member shall be max 1 in. (25 mm).

C. Gypsum Board* — Gypsum board sheets installed to a min total 5/8 in. (16 mm) or 1-1/4 in. (32 mm) thickness on each side of wall for 1 and 2 hr fire rated assemblies, respectively. Wall to be constructed as specified in the individual U400 Series Design in the UL Fire Resistance Directory, except that a max 1 in. (25 mm) gap shall be maintained between the top of the gypsum board and the spray applied fire resistive material on the steel floor units and between the top edge of the gypsum board and the spray applied fire resistive material on the structural steel support member. For D900 and P900 Series Designs, max separation between bottom of the steel floor units or roof deck and top of gypsum board (at time of installation of joint system) is 2 in. (51 mm). For D700 and P700 Series Designs, max separation between bottom of the spray applied fire resistive material on the steel floor units or roof deck and top of gypsum board (at time of installation of joint system) is 1 in. (25 mm). The screws attaching the gypsum board to studs at the top of the wall shall be located 1 in. (25 mm) below the bottom of the deflection channel, when deflection channel is used. When deflection channel is not used, the screws attaching the gypsum board to studs at the top of the wall shall be located 1 in. (25 mm) below the bottom of the ceiling runner.

The hourly fire rating of the joint system is equal to the hourly fire rating of the wall.

3. Joint System — Max separation between spray applied fire resistive material on bottom of structural support member and framed opening in top of wall is 1 in. (25 mm). For D700 and P700 series Designs, max separation between bottom of the spray applied fire resistive material on the steel floor units or roof deck and top of gypsum board (at time of installation of joint system) is 1 in. (25 mm). For D900 and P900 Series Designs, max separation between bottom of steel floor units or roof deck and top of gypsum board (at time of installation of joint system) is 2 in. (51 mm). The joint system is designed to accommodate a max 25 percent compression or extension from its installed width as measured between the spray applied fire resistive material on the steel floor units or roof deck and the top of the gypsum board. The joint system shall consist of forming and fill materials, with or without a deflection channel (Item 3A), as follows:

A. Deflection Channel — (Optional, Not Shown) - Min 24 gauge galv steel channel, 3 in. (76 mm) deep, sized to accommodate ceiling runner (Item 2A). Deflection channel to be centered beneath and parallel with valley of steel floor unit and secured to steel floor unit or roof deck with steel fasteners or welds spaced max 24 in. (610 mm) OC. The ceiling runner (Item 2A) is installed within the deflection channel to maintain a 1/2 in. (13 mm) to 1 in. (25 mm) gap between the top of the ceiling runner and the top of the deflection channel. A clearance of 1 in. (25 mm) shall be maintained between the end of the deflection channel and the spray applied fire resistive material on the structural steel support members. The ceiling runner nests inside the deflection channel without attachment.

B. Forming Material* — Nom 4 pcf (64 kg/m³) mineral wool batt insulation cut to a length approx the same as the overall thickness of wall and inserted cut edge first into the spaces between the spray-applied fire resistive material on the structural steel member and the framed notch at the top of the wall, flush with the gypsum board surface on both sides of the wall. The thickness of forming material shall be sufficient to attain a min compression of 33 percent between the sides of the framed notch and the protected structural steel member and a min compression of 50 percent between the bottom of the framed notch and the bottom of the protected structural steel member. Additional sections of mineral wool batt insulation are compressed 50 percent in thickness and are installed cut edge first to completely fill the gap above the top of the gypsum board, flush with both surfaces of wall.

IIG MINWOOL L L C — MinWool-1200 Safing

ROCK WOOL MANUFACTURING CO — Delta Safing Board

ROCKWOOL MALAYSIA SDN BHD — SAFE

ROXUL INC — SAFE

THERMAFIBER INC — SAF

C. Fill, Void or Cavity Material* - Sealant — Min 1/8 in. (3.2 mm) wet thickness or 1/16 in. (1.6 mm) dry wet thickness of fill material sprayed or brushed over the forming material on each side of the wall. Fill material to overlap a min of 1 in. (25 mm) onto the gypsum board and a min 2 in. (51 mm) onto the spray applied material (Item 1D) on the steel floor unit or roof deck and on the structural steel support member on both sides of wall.

RECTORSEAL — FlameSafe FS3000, Metacaulk 1200, 1500 or Biostop 750, 800 Spray

* Indicates such products shall bear the UL or cUL Certification Mark for jurisdictions employing the UL or cUL Certification (such as Canada), respectively.