



System No. HW-D-0188

March 29, 2006

Assembly Ratings — 1 and 2 Hr

Max Joint Width - 2 In.

Class II Movement Capabilities - 20 % Compression or Extension

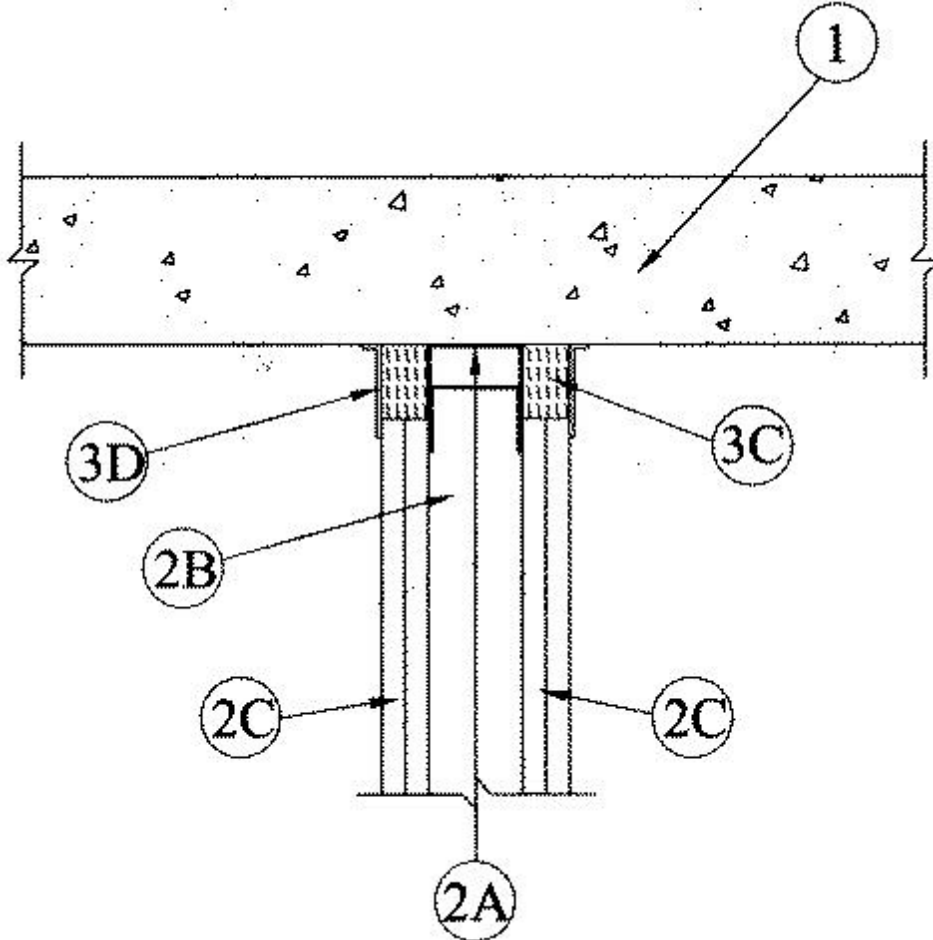

1. **Floor Assembly** — Min 4-1/2 in. thick steel reinforced lightweight or normal weight (100-150 pcf) structural concrete. Floor may also be constructed of any min 6 in. thick UL Classified hollow-core **Precast Concrete Units*** .

See **Precast Concrete Units** (CFTV) category in the Fire Resistance Directory for names of manufacturers

2. **Wall Assembly** — The 1 or 2 hr fire rated gypsum board/steel stud wall assembly shall be constructed of the materials and in the manner described in the individual U400 Series Wall or Partition Design in the UL Fire Resistance Directory and shall include the following construction features:

A. Steel Floor and Ceiling Runners — Floor and ceiling runners of wall assembly shall consist of galv steel channels sized to accommodate steel studs (Item 2B). Ceiling runner to be provided with 1 in. flanges. When U-shaped deflection channel (Item 3A) is used, ceiling runner installed within the U-shaped deflection channel with a 1-1/2 in. gap maintained between the top of ceiling runner and top of deflection plate. When deflection channel is not used, the ceiling runner shall have min 2-3/4 in. flanges. Ceiling runner secured to floor assembly with steel fasteners spaced a max 12 in. OC.

B. Studs — Steel studs to be min 3-1/2 in. wide. Studs cut 1-1/2 in. less in length than assembly height. When deflection channel is used, studs shall be installed with bottom nesting in and resting on floor runner and with top nesting in ceiling runner. Studs secured to floor and

ceiling runner with sheet metal screw. As an alternate to securing the studs to the ceiling runner, the ceiling runner may be notched with the Snip N\ Slide™ tool used to provide positive securement of the studs within the ceiling runner without the screws. When deflection channel is not used, studs shall be secured to ceiling runner, however, the ceiling runner may be notched with the Snip N\ Slide™ tool. Stud spacing not to exceed 24 in. OC.

C. Batts and Blankets* — (Not Shown) Mineral wool or fiberglass insulation batts, friction-fitted between studs and ceiling and floor runners, as required in the individual Wall and Partition Design.

D. Gypsum Board* — Gypsum board sheets installed to a min total thickness of 5/8 in. and 3/4 in. on each side of wall for 1 and 2 hr rated assemblies, respectively. Wall to be constructed as specified in the individual Wall and Partition Design in the UL Fire Resistance Directory, except that a nom 1-1/2 in. gap shall be maintained between the top of the gypsum board and the bottom of the steel floor units and the top row of screws shall be installed into the studs 4 to 4-1/2 in. below the lower surface of the floor.

3. Joint System — Max separation between bottom of floor and top of wall at time of installation of joint system is 2 in. The joint system is designed to accommodate a max 20 percent compression or extension from its installed width. The joint system consists of an optional deflection channel, gypsum wallboard strips, a forming material and a fill material, as follows:

A. Deflection Channel — (Optional) A nom 3-11/16 in. wide by 3 in. deep min No. 22 gauge steel U-shaped channel. Deflection channel secured to floor assembly with steel fasteners (Item 1A) spaced max 12 in. OC. The ceiling runner (Item 2A) is installed within the deflection channel to maintain a 1-1/2 in. gap between the top of the ceiling runner and the top of the deflection channel. The ceiling runner is not fastened to the deflection channel.

B. Gypsum Board* — When the thickness of gypsum board installed on each side of wall is less than 1-1/4 in., a min 12 in. wide strip of min 1/2 in. thick gypsum board shall be installed over the full sheets of gypsum board on each side of wall. The top edge of the strip shall be flush with the top edge of the full sheets and shall be secured to steel studs with 1-5/8 in. long Type S steel screw spaced max 6 in. OC. Strip also secured to full sheets midway between studs with 1-5/8 in. long Type G steel laminating screws spaced max 6 in. OC vertically. Uppermost screw securing the strip shall be located 4 to 4-1/2 in. below the lower surface of the floor. Joints of strip to be offset from joints of full sheets. Joints covered with paper tape and joint compound.

See **Gypsum Board** (CKNX) category for names of manufacturer.

C. Forming Material* — Min 1-1/4 in. thickness of min 4 pcf mineral wool insulation cut larger than the the max 2 in. wide gap above the top of the gypsum wallboard, compressed 33 percent in width, and firmly packed into the flutes and the gap between the top of the wallboard and the bottom of the floor assembly, flush with both surfaces of the wall.

ROCK WOOL MANUFACTURING CO —Delta Board

D. Fill, Void or Cavity Material* — Min 1/8 in. wet thickness of fill material sprayed or troweled on each side of the wall to completely cover mineral wool forming material and to overlap a min of 1/2 in. onto wallboard and concrete floor on both sides of wall.

RECTORSEAL — Biostop 750 Spray, Biostop 750 Caulk Grade

*Bearing the UL Classification Mark