

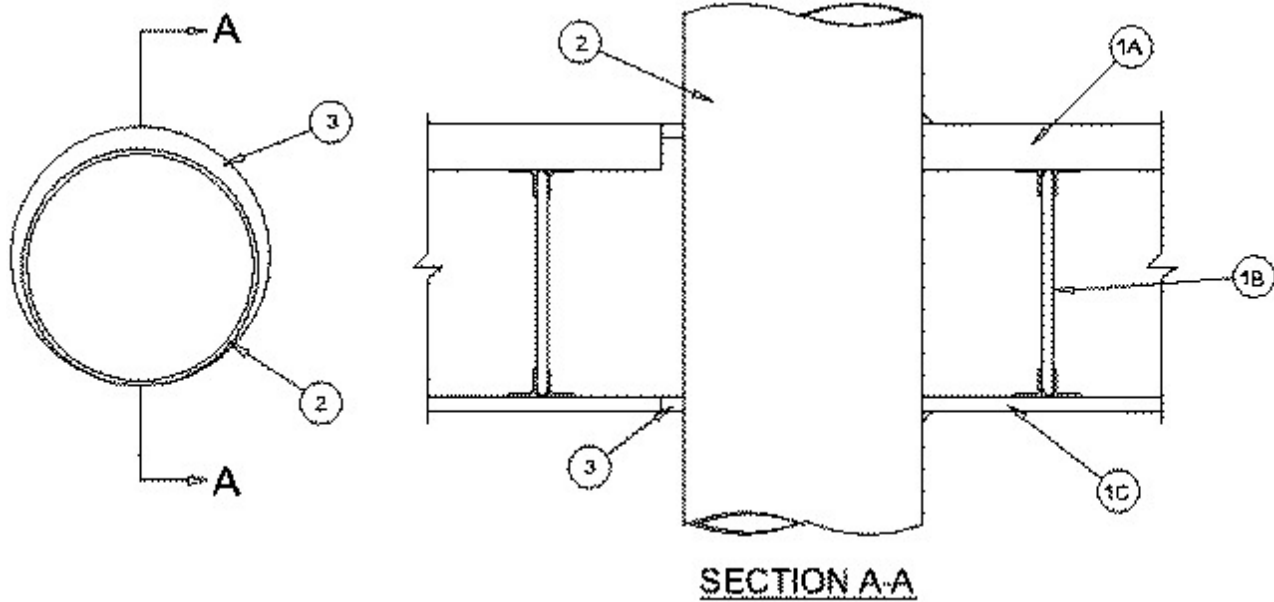

### System No. F-E-7003

July 15, 2014

ANSI/UL1479 (ASTM E814)	CAN/ULC S115
F Ratings - 1 Hr	F Ratings - 1 Hr
T Ratings - 1 Hr	FT Ratings - 1 Hr
	FH Ratings - 1 Hr
	FTH Ratings - 1 Hr
L Rating At Ambient - Less Than 1 CFM/sq ft	L Rating At Ambient - Less Than 1 CFM/sq ft
L Rating At 400 F - Less Than 1 CFM/sq ft	L Rating At 400 F - Less Than 1 CFM/sq ft



**1. Floor-Ceiling Assembly** — The 1 hr fire-rated concrete and steel joist Floor-Ceiling assembly shall be constructed of the materials and in the manner described in the individual G500 Series Design in the UL Fire Resistance Directory, as summarized below:

**A. Concrete Floor** — Normal weight or lightweight (100-150 pcf or 1600-2400 kg/m<sup>3</sup>) concrete over metal lath or steel deck as specified in the individual G500 Series Design. Max diam of floor opening is 6-1/2 in. (165 mm).

**B. Joists** — Steel joists or **Structural Steel members\*** as specified in the individual G500 Series Design.

**C. Gypsum Board\*** — Min 5/8 in. (16 mm) thick, screw-attached to furring channels as specified in the individual G500 Series Design. Max diam of ceiling is 6-1/2 in. (165 mm).

**2. Through Penetrant** — Nom 6 in. (153 mm) diam (or smaller) by No. 30 MSG (or heavier) steel duct. One steel duct to be installed either concentrically or eccentrically within the firestop system. The annular space within the firestop system shall be a min 0 in. (point contact) to a max 1/2 in. (13 mm). Steel duct to be located approx midway between joists and rigidly supported on both sides of floor-ceiling assembly.

**3. Fill, Void or Cavity Materials\*** — **Sealant** — Min 3/4 in. (19 mm) thickness of fill material applied within the annulus, flush with top surface of floor. Min 5/8 in. (16 mm) thickness of fill material applied within the annulus, flush with bottom surface of ceiling. At point contact locations, min 1/4 in. (6 mm) diam bead of fill material applied at penetrant/concrete interface on top surface of floor and penetrant/gypsum board interface on bottom surface of ceiling.

**RECTORSEAL** — FS 900+ Sealant, Metacaulk MC 150+, Biostop BF 150+

**\* Indicates such products shall bear the UL or cUL Certification Mark for jurisdictions employing the UL or cUL Certification (such as Canada), respectively.**