

System No. F-C-3060

July 15, 2014

ANSI/UL1479 (ASTM E814)	CAN/ULC S115
F Ratings - 1 and 2 Hr (See Item 1)	F Ratings - 1 and 2 Hr (See Item 1)
T Ratings - 0 Hr	FT Ratings - 0 Hr
	FH Ratings - 1 and 2 Hr (See Item 1)
	FTH Ratings - 0 Hr
L Rating At Ambient - Less Than 1 CFM/sq ft	L Rating At Ambient - Less Than 1 CFM/sq ft
L Rating At 400 F - 1.4 CFM/sq ft	L Rating At 400 F - 1.4 CFM/sq ft

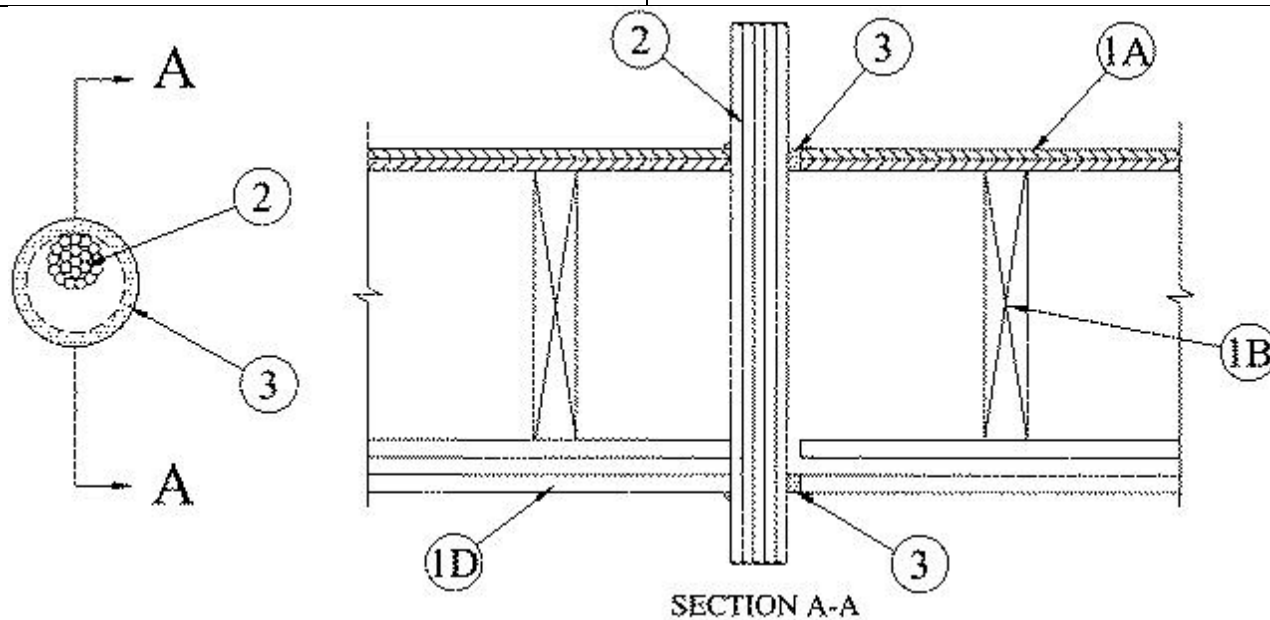

1. Floor Ceiling Assembly — The 1 hr fire-rated solid or trussed lumber joist floor-ceiling assembly shall be constructed of the materials and in the manner specified in the individual L500 Series Floor-Ceiling Designs in the UL Fire Resistance Directory. The 2 hr fire-rated wood joist floor-ceiling assembly shall be constructed of the materials and in the manner specified in Design Nos. L505, L511 or L536 in the UL Fire Resistance Directory. The general construction features of the floor-ceiling assembly are summarized below:

A. Flooring System — Lumber or plywood subfloor with finish floor of lumber, plywood or Floor Topping Mixture* as specified in the individual Floor-Ceiling Design. Max diam of floor opening is 4 in. (102 mm).

B. Wood Joists* — For 1 hr fire-rated floor-ceiling assemblies nom 10 in. (254 mm) deep (or deeper) lumber, steel or combination lumber and steel joists, trusses or Structural Wood Members* with bridging as required and with ends fireblocked. For 2 hr fire-rated floor-ceiling assemblies, nom 2 by 10 in. (51 by 254 mm) lumber joists spaced 16 in. (406 mm) OC with nom 1 by 3 in. (25 by 76 mm) lumber bridging and with ends fireblocked.

C. Furring Channels (Not Shown) — In 2 hr fire-rated assemblies, resilient galv steel furring installed perpendicular to wood joists between first and second layers of gypsum board (Item 1D). Furring channels spaced max 24 in. (610 mm) OC. In 1 hr fire-rated assemblies, resilient galv steel furring installed perpendicular to wood joists between gypsum board and wood joists as specified in the individual Floor-Ceiling Design. Furring channels spaced max 24 in. (610 mm) OC.

D. Gypsum Board* — Nom 4 ft (1.2 m) wide by 5/8 in. (16 mm) thick as specified in the individual Floor-Ceiling Design. First layer of gypsum board secured to wood joists or furring

channels as specified in the individual Floor-Ceiling Design. Second layer of gypsum board (2 hr fire-rated assembly) screw-attached to furring channels as specified in the individual Floor-Ceiling Design. Max diam of ceiling opening is 4 in. (102 mm).

The F Rating of the firestop system is equal to the hourly fire rating of the floor-ceiling assembly in which it is installed.

1.1 Chase Wall — (Optional, Not Shown) — The through penetrants (Item 2) may be routed through a 1 or 2 hr fire-rated single, double or staggered wood stud/gypsum board chase wall having a fire rating consistent with that of the floor-ceiling assembly. The chase wall shall be constructed of the materials and in the manner specified in the individual U300 Series Wall and Partition Designs in the UL Fire Resistance Directory and shall include the following construction features:

A. Studs — Nom 2 by 6 in. (51 by 152 mm) lumber or double nom 2 by 4 in. (51 by 102 mm) lumber studs.

B. Sole Plate — Nom 2 by 6 in. (51 by 152 mm) lumber or parallel 2 by 4 in. (51 by 102 mm) lumber plates, tightly butted.

C. Top Plate — The double top plate shall consist of two nom 2 by 6 in. (51 by 152 mm) lumber plates or two sets of nom 2 by 4 in. (51 by 102 mm) lumber plates tightly butted. Max diam of opening is 4 in. (102 mm).

D. Gypsum Board* — Thickness, type, number or layers and fasteners shall be as specified in individual Wall and Partition Designs.

2. Cables — Max 3-1/2 in. (89 mm) diam bundle tight bundle of cables to be installed either concentrically or eccentrically within the firestop system. The annular space between cable bundle and the periphery of the opening shall be a min 0 in. (point contact) to max 1/2 in. (13 mm). Penetrants to be rigidly supported on both sides of floor-ceiling assembly. The following types and sizes of cables may be used:

A. Max 100 pair No. 24 AWG (or smaller) copper conductor telecommunication cable with PVC insulation and jacketing.

B. Max 3/C No. 2/0 AWG (or smaller) aluminum conductor SER cable with PVC insulation and jacketing.

C. Max 3/C with ground No. 12 AWG (or smaller) Type NM (Romex) nonmetallic sheathed cable with PVC insulation and jacketing.

D. Max 7/C No. 12 AWG (or smaller) power/control cables with PVC insulation and jacketing.

E. Max RG/U (or smaller) copper conductor coaxial cable with fluorinated ethylene insulation and jacketing materials.

2A. Through Penetrating Products* — Max 4/C with ground No. 2 AWG (or smaller) aluminum or copper conductor aluminum jacketed Metal-Clad+ cable. Max one cable to be installed within the cable bundle. Max diam of cable bundle including this metal clad cable not to exceed 3-1/2 in. (89 mm).

GENERAL CABLE INDUSTRIES INC

3. Fill, Void or Cavity Material* — Sealant — Min 3/4 in. (19 mm) thickness of fill material applied within the annulus, flush with the top surface of the floor or sole plate. Min 5/8 in. (16 mm) thickness of fill material applied within the annulus, flush with bottom surface of ceiling or top plate. Fill material to forced within interstices of cable bundle to max extent possible. At point contact, min 3/8 in. (10 mm) diam bead of fill material applied at cable bundle/floor or sole plate interface and at cable bundle/ceiling or top plate interface. Additional sealant shall be applied in such a manner that the sealant overlaps a min 1/2 in. (13 mm) beyond the periphery of the opening on the top surface of the floor or sole plate and bottom surface of ceiling or bottom top plate.

RECTORSEAL — FS900+ Sealant, Metacaulk MC 150+, Biostop BF 150+

*** Indicates such products shall bear the UL or cUL Certification Mark for jurisdictions employing the UL or cUL Certification (such as Canada), respectively.**

+Bearing the UL Listing Mark