

System No. F-C-2330

September 27, 2005

F Rating — 1 Hr

T Rating — 1 Hr

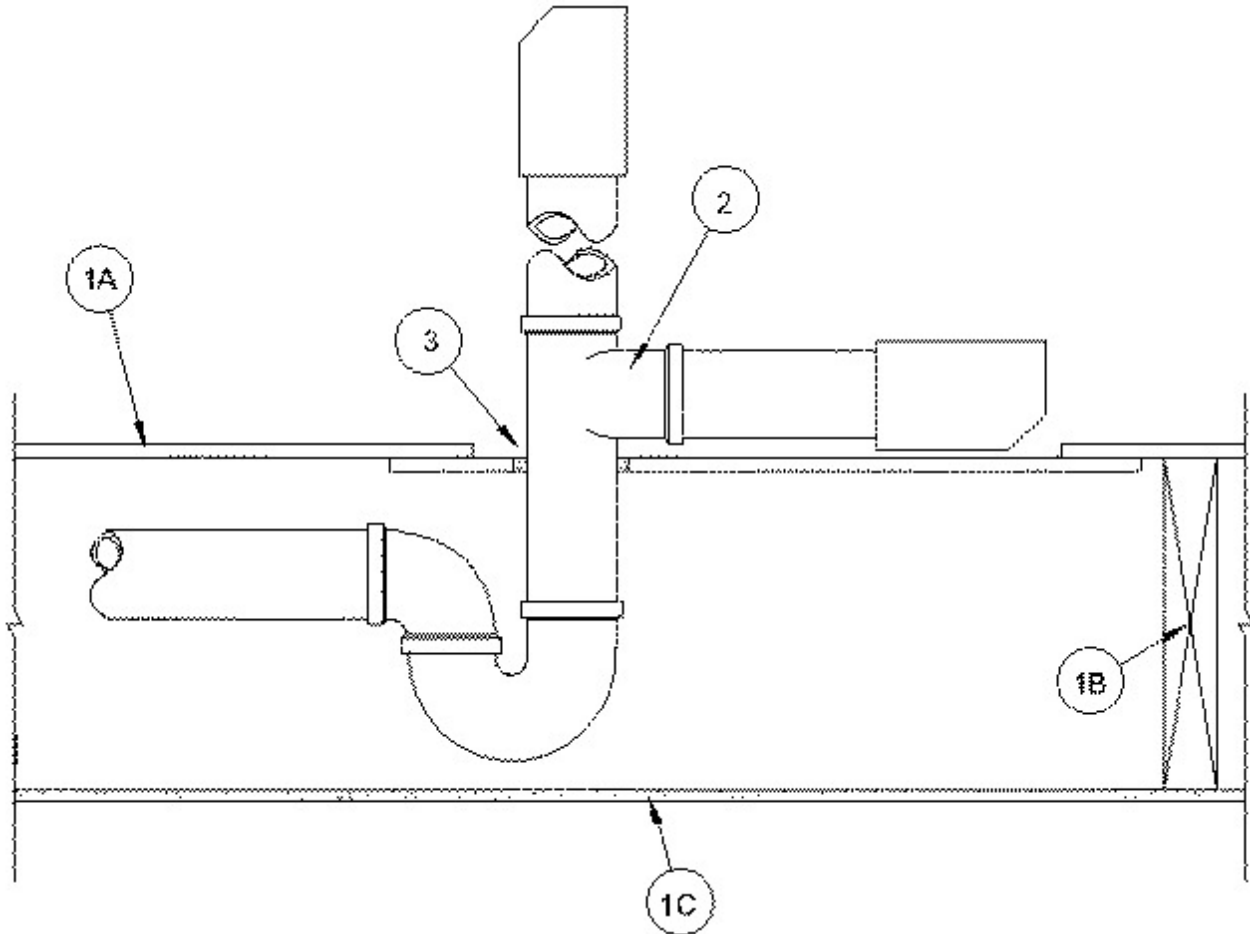

1. Floor-Ceiling Assembly — The 1 hr fire-rated wood joist floor-ceiling assembly shall be constructed of the materials and in the manner specified in individual L500 Series Designs in the UL Fire Resistance Directory. The general construction details of the floor-ceiling assembly are summarized below:

A. Flooring System — Lumber or plywood subfloor with finish floor of lumber, plywood or **Floor Topping Mixture*** as specified in the individual Floor-Ceiling Design. Rectangular cutout in flooring to accommodate the bathtub drain piping (Item 2) to be max 8 by 12 in. (203 by 305 mm). Cutout to be patched using one layer of min 3/4 in. (19 mm) thick plywood or min 5/8 in. (16 mm) thick gypsum wallboard (Item 1C). One piece of plywood or gypsum wallboard, min 2 in. (51 mm) longer and wider than the cutout in the flooring, cut in half in short dimension at opening hole-sawed for bathtub drain piping (Item 2). Two halves positioned below flooring, concentric with cutout, with cut edges tightly butted with no visible openings, and screw attached by means of 1-1/2 in. (38 mm) long laminate screw spaced max 6 in. (152 mm) OC. Diam of opening hole-sawed through patch to be 3/8 in. (10 mm) larger than outside diam of bathtub drain piping.

B. Wood Joists — Nom 10 in. (254 mm) deep (or deeper) lumber, steel or combination lumber and steel joists, trusses or **Structural Wood Members*** with bridging as required and with ends firestopped.

C. Gypsum Board* — Nom 5/8 in. (16 mm) thick as specified in the individual Floor-Ceiling Design. Wallboard secured to joists as specified in the individual Floor-Ceiling Design.

2. **Drain Piping** — Nom 1-1/2 in. (38 mm) diam (or smaller) Schedule 40 cellular or solid core polyvinyl chloride (PVC) or acrylonitrile butadiene styrene (ABS) pipe and drain fittings cemented together and provided with PVC or ABS bathtub waste/overflow fittings. The annular space shall be min 1/8 in. (3.2 mm) to max 3/16 in. (4.8 mm).

3. **Fill, Void or Cavity Material* - Caulk** — Min 3/4 or 5/8 in. (19 or 16 mm) thickness of fill material applied within annulus flush with top surface of plywood or gypsum wallboard patch, respectively.

RECTORSEAL — Biostop 350i

*Bearing the UL Classification Mark