

System No. C-AJ-8176

September 27, 2005

F Rating — 2 Hr

T Rating — 0 Hr

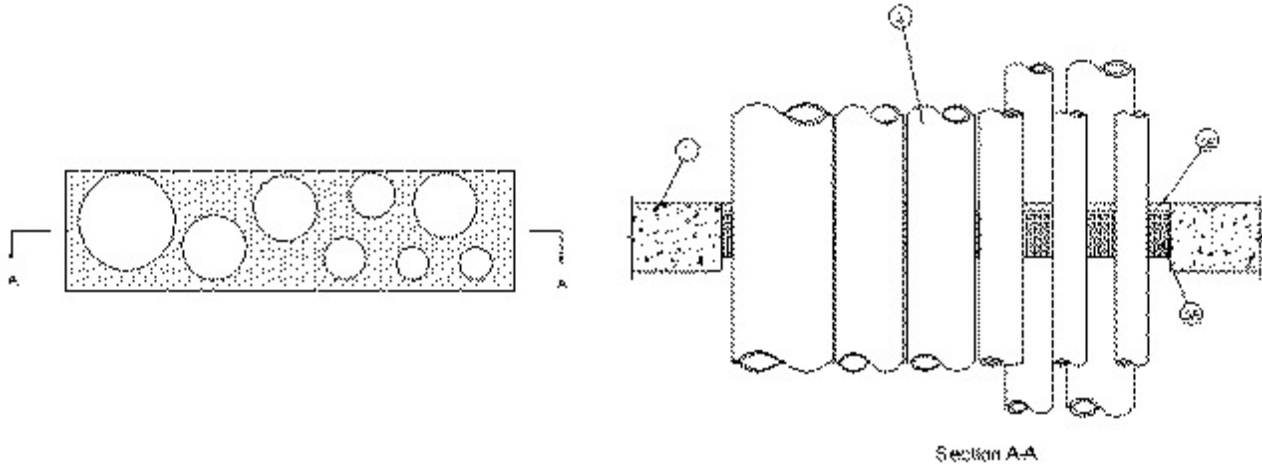

1. **Floor or Wall Assembly** — Min 4-1/2 in. (114 mm) thick reinforced lightweight or normal weight (100-150 pcf or 1600-2400 kg/m³) concrete floor. Wall may also be constructed of any UL classified **Concrete Blocks***. Max area of opening is 240 sq in. (0.155 m²) with max dimension of 30 in. (762 mm).

See **Concrete Blocks** (CAZT) category in the Fire Resistance Directory for names of manufacturers.

2. **Through-Penetrants** — Max eight pipes, conduits or tubing to be installed within the opening. The space between pipes, conduits or tubing shall be a min 1/2 in. (13 mm) to max 2-3/4 in. (70 mm). The space between pipes, conduits or tubing and periphery of opening shall be min 0 in. (point contact) to max 3-1/4 in. (83 mm). Penetrants to be rigidly supported on both sides of floor or wall assembly. The following types and sizes of pipes, conduits or tubing may be used:

- A. **Steel Pipe** — Nom 6 in. (152 mm) diam (or smaller) Schedule 10 (or heavier) steel pipe.
- B. **Copper Pipe** — Nom 3 in. (76 mm) diam (or smaller) regular (or heavier) copper pipe.
- C. **Copper Tubing** — Nom 3 in. (76 mm) diam (or smaller) Type L (or heavier) copper tubing.
- D. **Conduit** — Nom 4 in. (102 mm) diam (or smaller) steel electrical metallic tubing or rigid steel conduit.
- E. **Flexible Metal Gas Pipe** — Nom. 2 in. (51 mm) diam (or smaller) with PVC jacket

GASTITE, DIV OF TITFLEX

3. **Firestop System** — The firestop system shall consist of the following:

A. **Packing Material** — Min 3 in. (76 mm) thickness of min 4 pcf (64 kg/m³) mineral wool batt insulation firmly packed into opening as a permanent form. Packing material to be recessed from top surface of floor or both surfaces of wall to accommodate the required thickness of fill material.

B. **FFill, Void or Cavity Material* - Caulk** — Min 1/2 in. (13 mm) thickness of fill material applied within the annulus, flush with top surface of floor and both surfaces of wall. When min 4 in. (102 mm) of min 4 pcf (64 kg/m³) mineral wool batt insulation is used as described above, thickness of fill material may be reduced to 1/4 in. (6 mm). A min 1/4 in. (6 mm) diam bead of caulk shall be applied to the penetrant/concrete interface at the point contact location on the top surface of floor or both surfaces of wall.

*Bearing the UL Classification Mark