

System No. C-AJ-5298

September 27, 2005

F Rating — 2 Hr

T Rating — 3/4 Hr

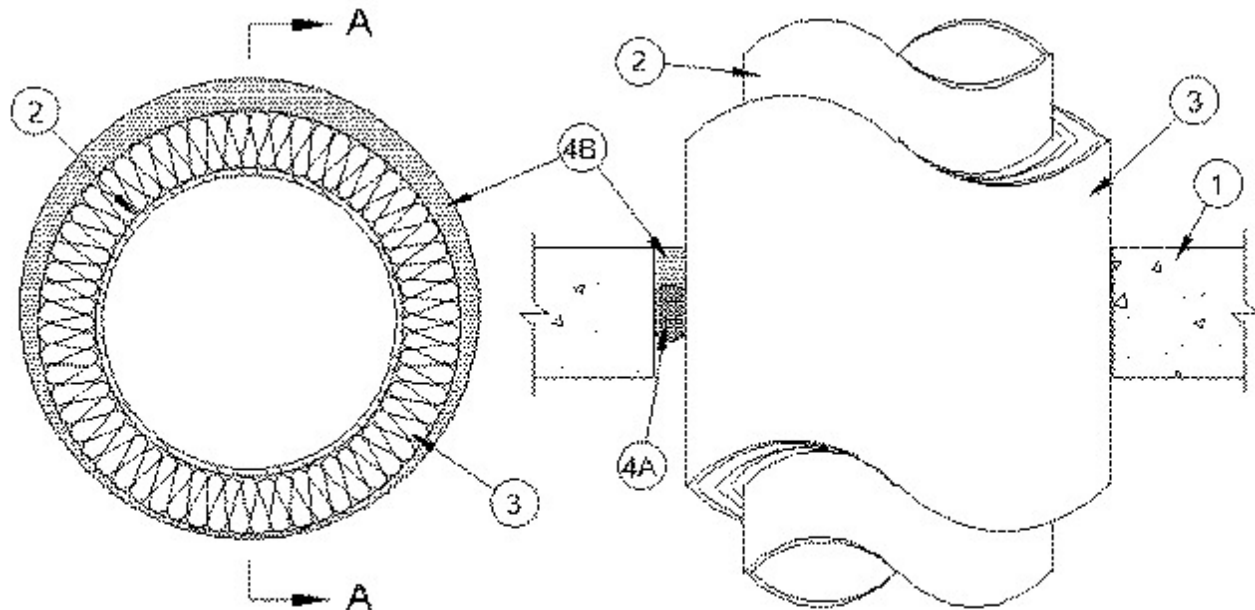

Section A-A

1. **Floor or Wall Assembly** — Min 4-1/2 in. (114 mm) thick reinforced lightweight or normal weight (100-150 pcf or 1600-2400 kg/m³) concrete. Wall may also be constructed of any UL Classified **Concrete Blocks***. Floor may also be constructed of any 6 in. (152 mm) thick UL Classified hollow-core **Precast Concrete Units***. Max diam of opening is 16 in. (406 mm). When precast concrete units are use, max diam of opening is 7 in. (178 mm).

See **Concrete Blocks** (CAZT) and **Precast Concrete Units** (CFTV) categories in the Fire Resistance Directory for names of manufacturers.

2. **Through Penetrants** — One metallic pipe or tubing to be installed concentrically or eccentrically within the firestop system. Pipe or tubing to be rigidly supported on both sides of floor or wall assembly. The following types and sizes of metallic pipes or tubing may be used:

- A. **Steel Pipe** — Nom 10 in. (254 mm) diam (or smaller) Schedule 10 (or heavier) steel pipe.
- B. **Iron Pipe** — Nom 10 in. (254 mm) diam (or smaller) cast or ductile iron pipe.
- C. **Copper Tubing** — Nom 4 in. (102 mm) diam (or smaller) Type L (or heavier) copper tubing.
- D. **Copper Pipe** — Nom 4 in. (102 mm) diam (or smaller) Regular (or heavier) copper pipe.

3. **Pipe Covering*** — Nom 2 in. (51 mm) thick hollow cylindrical heavy density (3.5 pcf or 56 kg/m³) glass fiber units jacketed on the outside with an all service jacket. Longitudinal joints sealed with metal fasteners or factory-applied self-sealing lap tape. Transverse joints secured with metal fasteners or with butt tape supplied with the product. The annular space between insulated pipe and periphery of opening shall be min 1/4 in. (6 mm) to max 1 in. (25 mm).

See **Pipe and Equipment Covering** — Materials (BRGU) category in the Building Materials Directory for names of manufacturers. Any pipe covering material meeting the above specifications and bearing the UL Classification Marking with a Flame Spread Index of 25 or less and a Smoke Developed Index of 50 or less may be used.

4. **Firestop System** — The firestop system shall consist of the following:

A. **Packing Material** — Foam backer rod firmly packed into opening as a permanent form. Packing material to be recessed from top surface of solid concrete floor or from both surfaces of wall or hollow-core floor to accommodate the required thickness of fill material.

B. **Fill, Void or Cavity Material* - Caulk** — Min 1-1/4 in. (32 mm) thickness of fill material applied within the annulus, flush with top surface of solid concrete floor or with both surfaces of wall or hollow-core floor.

RECTORSEAL — Biostop 350i

* Indicates such products shall bear the UL or cUL Certification Mark for jurisdictions employing the UL or cUL Certification (such as Canada), respectively.