



### System No. C-AJ-3257

September 27, 2005

F Rating — 2 Hr

T Ratings — 1/4 and 1/2 Hr (See Item 2)

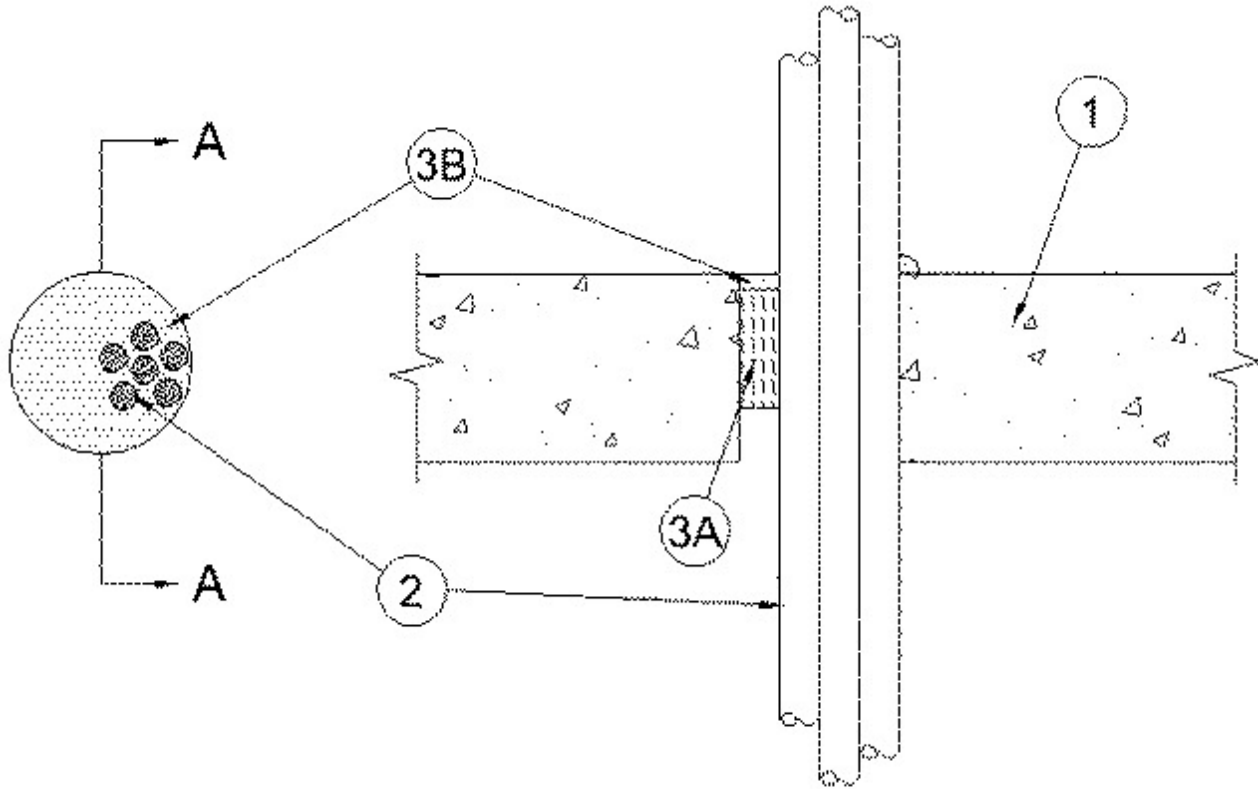

SECTION A-A

1. **Floor or Wall Assembly** — Min 4-1/2 in. (114 mm) thick reinforced lightweight or normal weight (100-150 pcf or 1600-2400 kg/m<sup>3</sup>) concrete. Wall may also be constructed of any UL Classified **Concrete Blocks**<sup>\*</sup>. Max diam of opening is 4 in. (102 mm).

See **Concrete Blocks** (CAZT) category in the Fire Resistance Directory for names of manufacturers.

2. **Cables** — Aggregate cross-sectional area of cables in opening to be min 10 percent to max 66 percent of the aggregate cross-sectional area of the opening. Cables to be tightly bundled and rigidly supported on both sides of floor or wall assembly. The annular space between the cable bundle and the periphery of the opening shall be a min 0 in. (point contact) to a max 1-3/4 in. (44 mm). Any combination of the following types and sizes of cables may be used:

A. Max 2/C No. 12 AWG MC (BX) cable with copper conductors and polyvinyl chloride (PVC) insulation.

B. Max 3/C No. 8 AWG (or smaller) nonmetallic sheathed (Romex) cable with copper conductors, PVC insulation and jacket.

C. Max 3/C with ground, No. 10 AWG (or smaller) nonmetallic sheathed (Romex) cable with copper conductors, PVC insulation and jacket.

D. Max 25 pair No. 20 AWG (or smaller) copper conductor cable with XLPE/PVC insulation, with or without PVC jacket.

E. Max RG59/U (or smaller) coaxial cable with aluminum or copper conductors and fluorinated ethylene insulation and jacketing.

F. Max 4 pair No. 24 AWG (or smaller) copper conductor data cable with Hylar insulation and jacketing.

G. Max 2/C No. 22 AWG (or smaller) copper conductor alarm cable with PVC insulation.

H. Max 1/C No. 14 AWG (or smaller) copper conductor Type MTW or THHN or THWN or gas & oil res II 600V (UL) or AWM VW-1 power cable.

I. Max 1/C No. 10 AWG (or smaller) copper conductor Type THHN or THWN gasoline & oil resistant II 600V VW-1 E116364 (UL) power cable.

J. Max 4/C No. 18 AWG bimetal conductors Type CL-2 Barostat II Sun res (UL) Listed thermostat cable.

K. Max 3/C No. 4 AWG aluminum Triple E Alloy AA8176 Type SE cable Style U Type XHH-W-2 CDRS E32071 (UL) service entrance cable.

L. Max 1/C 300 MCM type MTW or THHN or THWN for CT use gas & oil res. II sun res. 600V (UL) or AWM, 300 kcmil, copper conductor power cable.

M. Max 6/C Commscope Optical Reach 2001 006 fiber optic cable.

N. Max 3/C No. 18 AWG copper Manhattan / CDT-F P/N M244826 E-120910 18 AWG Shielded CMP (UL) c(UL), Foil Shield, 300V power cable.

O. Max 4 pr No. 24 AWG copper Belden-M DataTwist (R) Five 1583A CM 4PR24, computer network cable.

**When annular space is greater than 3/4 in., the T Rating is 1/4 hr. When annular space is 3/4 in. or less, T Rating is 1/2 hr.**

**3. Firestop System** — The firestop system shall consist of the following:

**A. Packing Material** — Min 3 in. (76 mm) thickness of min 4 pcf (64 kg/m<sup>3</sup>) mineral wool batt insulation firmly packed into opening as a permanent form. Packing material to be recessed from top surface of floor or from both surfaces of wall to accommodate the required thickness of fill material.

**B. Fill, Void or Cavity Material\* - Caulk** — Min 1/4 in. (6mm) thickness of fill material applied within the annulus, flush with top surface of floor or both surfaces of wall. At point contact location between concrete floor or wall and cables, a min 1/2 in. (13 mm) diam bead of fill material shall be applied to the concrete/cable interface on top surface of floor or both surfaces of wall.

**RECTORSEAL** — Biostop 350i

\*Bearing the UL Classification Mark