



# System No. C-AJ-2629

June 29, 2009

F Rating — 2 Hr

T Ratings — 0, 1-1/2 Hr and 2 Hr (See Item 2)

L Rating At Ambient — 1.5, 2 or 3 CFM (See Item 2)

L Rating At 400 F — 1.5, 2 or 3 CFM (See Item 2)

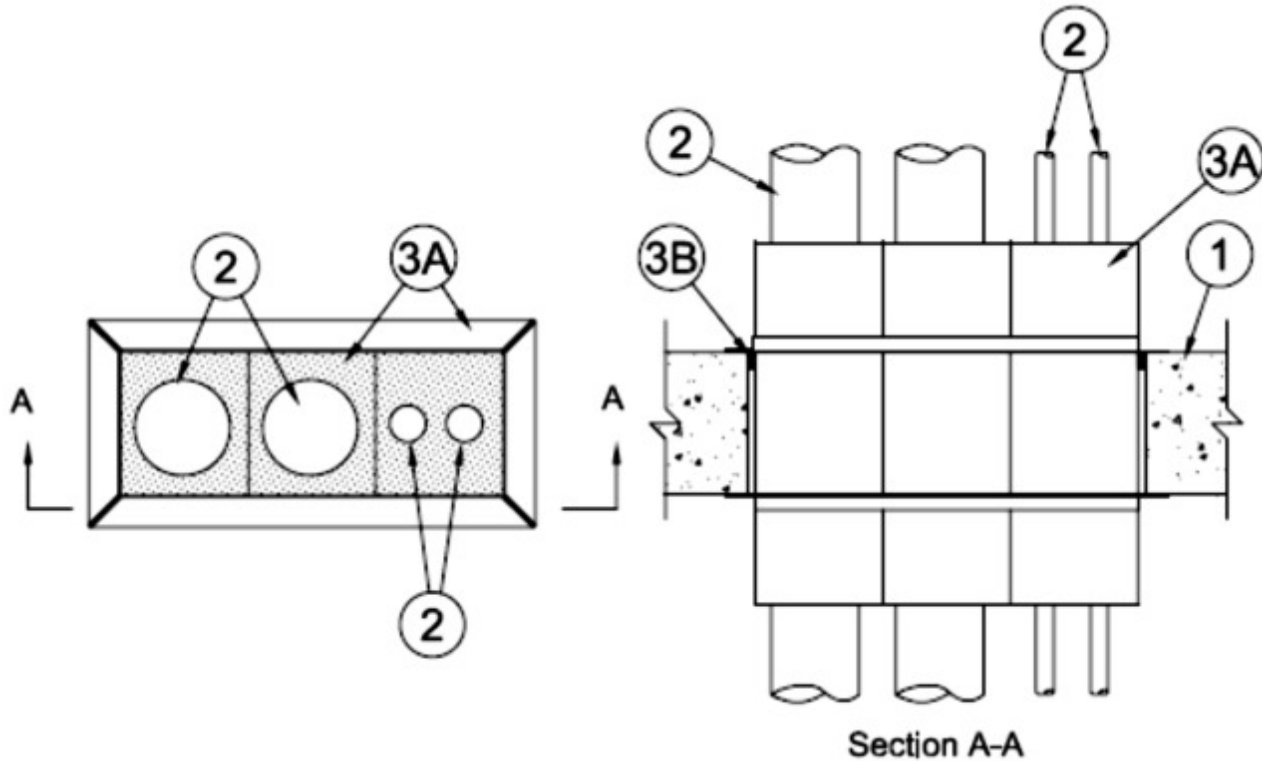

1. **Floor or Wall Assembly** — Min 4-1/2 in. (114 mm) thick reinforced lightweight or normal weight (100-150 pcf or 1600-2400 kg/m<sup>3</sup>) concrete. Wall may also be constructed of any UL Classified **Concrete Blocks**\*. Max area of opening is 56-1/4 in.2 (363 cm<sup>2</sup>) with a max dimension of is 12-1/2 in. (318 mm) for square devices.

See **Concrete Blocks** (CAZT) category in Fire Resistance Directory for names of manufacturers.

2. **Through-Penetrants** — One or more nonmetallic pipes, conduits or tubes as described in a single line item below, may be installed concentrically or eccentrically within each firestop device (Item 3A) without any limitation on annular space. If multiple through penetrants are installed within the firestop device, the through penetrants may be bundled together. **T Rating shall be the lesser of the T Ratings for the penetrants installed.** Through penetrants to be rigidly supported on both sides of floor or wall assembly. The following types and sizes of through penetrants may be used:

A. **Polyvinyl Chloride (PVC) Pipe** — One nom 2 in. (51 mm) diam (or smaller) Schedule 40 solid core PVC pipe for use in closed (process or supply) or vented (drain, waste or vent) piping systems. When PVC pipe is used, T Rating is 1-1/2 hr.

B. **Rigid Nonmetallic Conduit+** — One nom 2 in. (51 mm) diam (or smaller) Schedule 40 PVC conduit installed in accordance with Article 352 of the National Electrical Code (NFPA No. 70). When conduit is used, T Rating is 1-1/2 hr.

See **Rigid Nonmetallic, Schedule 40 and 80 PVC Conduit** (DZYR) category in the Electrical Construction Equipment Directory for names of manufacturers.

**C. Chlorinated Polyvinyl Chloride (CPVC) Pipe** — One nom 2 in. (51 mm) diam (or smaller) SDR11 CPVC pipe for use in closed (process or supply) piping systems. When CPVC pipe is used, T Rating is 1-1/2 hr.

**D. Crosslinked Polyethylene (PEX) Tubing** — One nom 2 in. (51 mm) diam (or smaller) SDR 9 PEX tubing for use in closed (process or supply) piping systems. When PEX tubing is used, T Rating is 0 hr.

**E. Electrical Nonmetallic Tubing (ENT)+** — One nom 2 in. (51 mm) diam (or smaller) and max two 1 in. (25 mm) diam (or smaller) ENT installed in accordance with Article 362 of the National Electrical Code (NFPA No. 70). When ENT is used, T Rating is 2 hr.

See **Electrical Nonmetallic Tubing (FKHU)** category in the Electrical Construction Equipment Directory for names of manufacturers.

**F. Optical Fiber/Communications/Signaling/Coaxial Cable Raceways+** — One nom 2 in. (51 mm) diam (or smaller) and max two 1 in. (25 mm) diam (or smaller) plenum rated raceways installed in accordance with the National Electrical Code (NFPA No. 70). When raceway is used, T Rating is 2 hr.

See **Optical Fiber/Communications/Signaling/Coaxial Cable Raceway (QAZM)** category in the Electrical Construction Equipment Directory for names of manufacturers.

**The L rating is 1.5, 2 or 3 CFM when 1, 2 or 3 or more devices contain penetrants respectively.**

**3. Firestop System** — The firestop system shall consist of the following:

**A. Firestop Device\*** — A max of three square firestop devices may be ganged together. Each device consists of a nom 2-1/2 by 2-1/2 by 10 in. (64 by 64 by 254 mm) or 4 by 4 by 10 in. (102 by 102 by 254 mm) powder coated steel transit incorporating internal intumescent material, foam plugs and mounting flanges. In 2 -1/2 by 2-1/2 in. (64 by 64 mm) devices, the max nom diam of the through penetrant shall not exceed 1-1/4 in. (32 mm). Firestop device(s) to be centered within opening and installed with ends projecting an equal distance beyond each surface of the floor or wall assembly in accordance with the accompanying installation instructions. The annular space between device(s) and periphery of opening shall be a nom 1/4 in. (6 mm). Firestop device(s) secured in place by means of fill material (Item 3B) and steel split mounting flanges sized to accommodate the firestop device. Steel split mounting flanges installed on both sides of floor or wall after installation of fill material and secured together with supplied steel set screws. Two nom 1 in. (25 mm) thick pre-cut foam plugs sized to accommodate the through penetrant and installed flush with each end of device on both sides of floor or wall assembly.

**RECTORSEAL** — Biostop ® 2" square Pass Through Device, Biostop ® 4" square Pass Through Device

**B. Fill, Void or Cavity Materials\* - Sealant** — Min 1 in. (25 mm) thickness of fill material applied within the annulus, flush with top surface of floor or both surfaces of wall prior to the installation of the mounting flanges.

**RECTORSEAL** — Biostop 500+ or Firerated putty.

+ Bearing the UL Listing Mark

\*Bearing the UL Classification Mark