



System No. C-AJ-2563

September 27, 2005

F Rating — 2 Hr

T Rating — 2 Hr

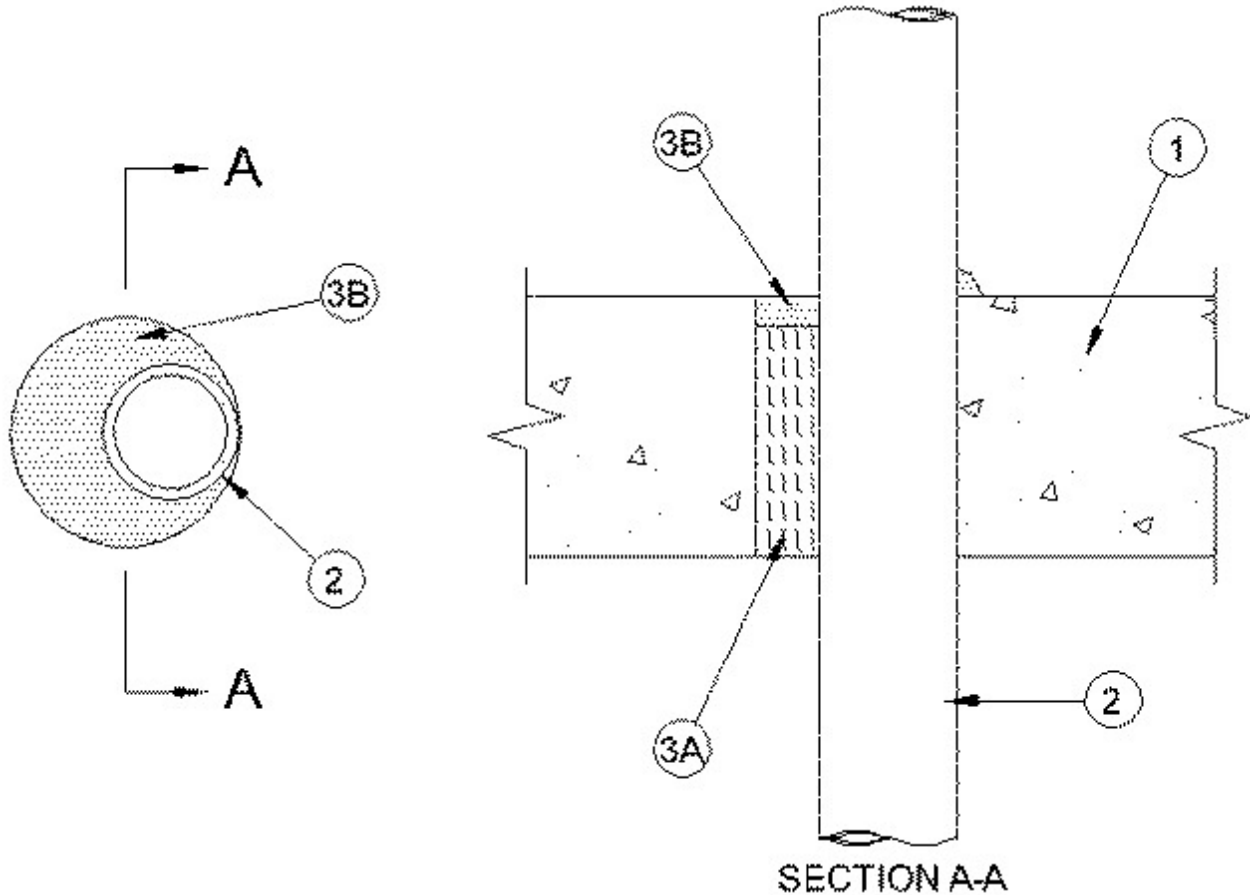

1. **Floor or Wall Assembly** — Min 4-1/2 in. (114 mm) thick reinforced lightweight or normal weight (100-150 pcf or 1600-2400 kg/m³) concrete floor or min 5 in. (127 mm) thick reinforced lightweight or normal weight concrete wall. Wall may also be constructed of any UL Classified **Concrete Blocks***. Max diam of opening is 4 in. (102 mm).

See **Concrete Blocks** (CAZT) category in the Fire Resistance Directory for names of manufacturers.

2. **Through Penetrating Product*** — One non-metallic pipe, installed concentrically or eccentrically within firestop system. The annular space between the pipe and periphery of opening shall be min 0 (point contact) to max 1-5/8 in. (41 mm). Pipe to be rigidly supported on both sides of floor or wall assembly. The following types and sizes of non-metallic pipes may be used:

A. **Polyvinyl Chloride (PVC) Pipe** — Nom 2 in. (102 mm) diam (or smaller) Schedule 40 solid core or cellular core PVC pipe for use in closed (process or supply) or vented (drain, waste or vent) piping systems.

B. **Chlorinated Polyvinyl Chloride (CPVC) Pipe** — Nom 2 in. (102 mm) diam (or smaller) SDR 13.5 CPVC pipe for use in closed (process or supply) piping systems.

C. **Acrylonitrile Butadiene Styrene (ABS) Pipe** — Nom 2 in. (102 mm) diam (or smaller) Schedule 40 solid core or cellular core ABS pipe for use in closed (process or supply) or vented (drain, waste or vent) piping systems.

3. **Firestop System** — The firestop system shall consist of the following:

A. **Packing Material** — Min 4 in. (102 mm) thickness of min 4 pcf (64 kg/m³) mineral wool batt insulation firmly packed into opening as a permanent form. Packing material to be recessed from top surface of floor or from both surfaces of wall to accommodate the required thickness of fill material.

B. **Fill, Void or Cavity Material* - Caulk** — Min 1/2 in. (13 mm) thickness of fill material applied within the annulus, flush with top surface of floor or with both surfaces of wall assembly. Min 1/4 in. (6 mm) diam bead of caulk applied to the penetrant/concrete interface at the point contact location on the top surface of floor or both surfaces of wall.

RECTORSEAL — Biostop 350i

*Bearing the UL Classification Mark