



System No. C-AJ-1604

June 29, 2009

F Ratings — 2 and 3 Hr (See Item 2)

T Rating — 0 Hr

L Rating At Ambient — 1.5, 2 or 3 CFM (see Item 2)

L Rating At 400 F — 1.5, 2 or 3 CFM (see Item 2)

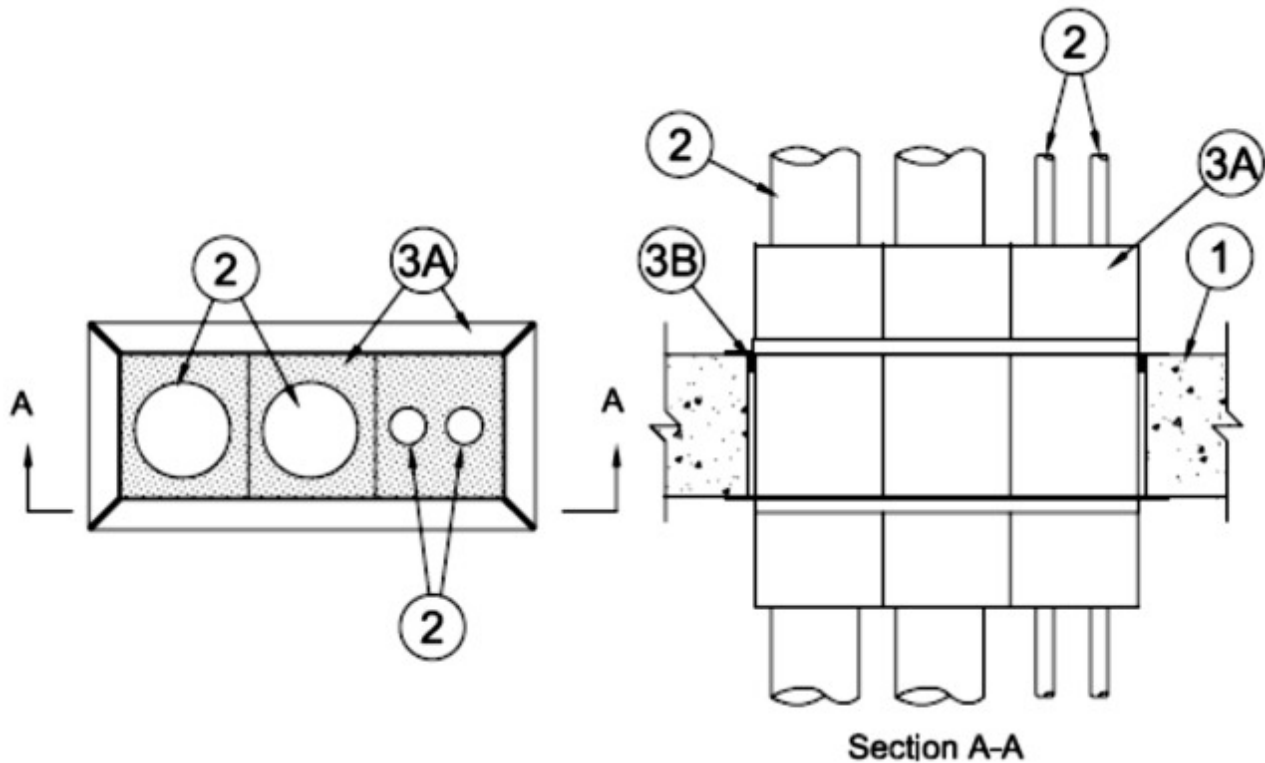

1. **Floor or Wall Assembly** — Min 4-1/2 in. (114 mm) thick reinforced lightweight or normal weight (100-150 pcf or 1600-2400 kg/m³) concrete. Wall may also be constructed of any UL Classified **Concrete Blocks**^{*}. Max area of opening is 56-1/4 in.² (363 cm²) with a max dimension of is 12-1/2 in. (318 mm).

See **Concrete Blocks** (CAZT) category in Fire Resistance Directory for names of manufacturers.

2. **Through-Penetrant** — One or more metallic pipe, tubing or conduit may be installed concentrically or eccentrically within each firestop device (Item 3A). If multiple through penetrants are installed within the firestop device, a min 1/4 in. (6 mm) annular space is required between the through penetrants. Through penetrants to be rigidly supported on both sides of floor or wall assembly. The following types and sizes of through penetrants may be used:

- A. **Steel Pipe** — Nom 3 in. (76 mm) diam (or smaller) Schedule 10 (or heavier) steel pipe.
- B. **Iron Pipe** — Nom 3 in. (76 mm) diam (or smaller) cast or ductile iron pipe.
- C. **Copper Tubing** — Nom 3 in. (76 mm) diam (or smaller) Type L (or heavier) copper tube.
- D. **Copper Pipe** — Nom 3 in. (76 mm) diam (or smaller) Regular (or heavier) copper pipe.
- E. **Conduit** — Nom 3 in. (76 mm) diam (or smaller) steel electric metallic tubing (EMT) or rigid steel conduit.

F. Through-Penetrating Product* - Flexible Metal Piping — Nom 1-1/4 in. (32 mm) diam (or smaller) steel flexible metal piping.

OMEGA FLEX INC — TracPipe Flexible Gas Piping

The F Rating of the firestop system is dependent upon the max nom diam of the through penetrant. If the max nom diam is nom 1-1/4 in. or less, the F Rating is 3 hr. If the max nom diam is greater than 1-1/2 in., the F Rating is 2 hr.

The L rating is 1.5, 2 or 3 CFM when 1, 2 or 3 or more devices contain penetrants respectively.

3. Firestop System — The firestop system shall consist of the following:

A. Firestop Device* — A max of three firestop devices may be ganged together. Each device consists of a nom 2-1/2 by 2-1/2 by 10 in. (64 by 64 by 254 mm) long or 4 by 4 by 10 in. (102 by 102 by 254 mm) long painted steel transit incorporating internal intumescent material, foam plugs and mounting flanges. In nom 2 -1/2 by 2-1/2 in. (64 by 64 mm) devices, the max nom diam of the through penetrant (Item 2) shall not exceed 1-1/4 in. (32 mm). Firestop device to be centered within opening and installed with ends projecting an equal distance beyond each surface of the floor or wall assembly in accordance with the accompanying installation instructions. The annular space between the firestop device(s) and the periphery of the opening shall be nom 1/4 in. (6 mm). Firestop devices secured in place by means of fill material (Item 3B) and steel split mounting flanges sized to accommodate the firestop device. Steel split mounting flanges installed on both sides of floor or wall after installation of fill material and secured to together with supplied steel set screws. Nom 1 in. (25 mm) thick foam plugs cut to accommodate the through penetrant(s) and installed flush with each end of device on both sides of floor or wall assembly.

RECTORSEAL — Biostop ® 2" square Pass Through Device, Biostop ® 4" square Pass Through Device

B. Fill, Void or Cavity Materials* — Min 1/8 in. (3 mm) thickness of fill material applied within the annulus, flush with top surface of floor or with both surfaces of wall.

RECTORSEAL — Biostop 500+ or Firerated putty

*Bearing the UL Classification Mark