

System No. C-AJ-1546

September 26, 2005

F Rating — 3 Hr

T Rating — 0 Hr

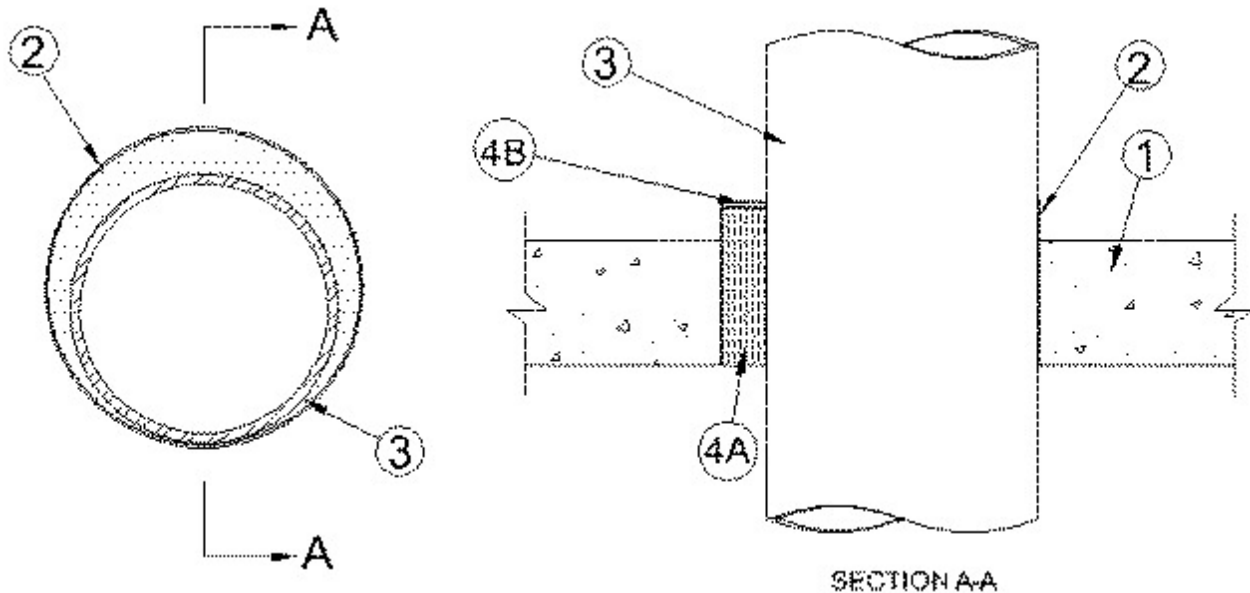

1. **Floor or Wall Assembly** — Min 4-1/2 in. (114 mm) thick reinforced lightweight or normal weight (100-150 pcf or 1600-2400kg/m³) concrete. Wall may also be constructed of any UL Classified **Concrete Blocks***.

See **Concrete Blocks** (CAZT) category for names of manufacturers.

2. **Steel Sleeve** — (Optional) - Nom 22 in. (559 mm) diam (or smaller) Schedule 5 (or heavier) steel. Length of steel sleeve to be 1-1/2 in. (38 mm) greater than thickness of floor or 3 in. (76 mm) greater than thickness of wall. Steel sleeve to project 1-1/2 in. (38 mm) beyond top surface of floor or both sides of wall.

3. **Through Penetrant** — One metallic pipe or conduit to be installed concentrically or eccentrically within the firestop system. The annular space between the through penetrant and the periphery of opening shall be min 0 in. (point contact) to a max of 1-3/4 in. (44 mm). Through penetrant to be rigidly supported on both sides of floor or wall assembly. The following types and sizes of metallic pipe or conduit may be used:

A. **Steel Pipe** — Nom 20 in. (508 mm) diam (or smaller) Schedule 10 (or heavier) steel pipe.

B. **Iron Pipe** — Nom 20 in. (508 mm) diam (or smaller) cast or ductile iron pipe.

C. **Steel Conduit** — Nom 6 in. (152 mm) diam (or smaller) rigid steel conduit or nom 4 in. (102 mm) diam (or smaller) steel electrical metallic tubing (EMT).

D. **Copper Tube** — Nom 6 in. (152 mm) diam (or smaller) Type L (or heavier) copper tubing.

E. **Copper Pipe** — Nom 6 in. (152 mm) diam (or smaller) Regular (or heavier) copper pipe.

4. **Firestop System** — The firestop system shall consist of the following:

A. **Packing Material** — When optional steel sleeve is used, min 5-3/4 in. (146 mm) thickness of min 4 pcf (64 kg/m³) mineral wool batt insulation firmly packed into annular space as a permanent form. When steel sleeve is not used, min thickness of mineral wool is 4-1/4 in. (108 mm). Packing material to be recessed min 1/4 in. (6 mm) from top of sleeve or concrete in floor or from both ends of sleeve or concrete in wall to accommodate the fill material (Item 5).

B. Fill, Void or Cavity Material* - Caulk — When optional steel sleeve is used, fill material applied to fill the annular space to a min depth of 1/4 in. (6 mm) flush with the top edge of steel sleeve in floor or both ends of steel sleeve in wall. When optional steel sleeve is not used, fill material applied to a min depth of 1/4 in. (6 mm) flush with top surface of floor or with both surfaces of wall. Min 1/4 in. (6 mm) diam bead of caulk applied to the penetrant/sleeve or concrete interface at the point contact location on the top surface of floor or both surfaces of wall.

RECTORSEAL — Biostop 350i

*Bearing the UL Classification Mark