



## System No. C-AJ-0133

June 30, 2009

F Rating — 2 Hr

T Rating — 1-1/2 Hr

L Rating At Ambient — Less than 1 CFM

L Rating At 400 F — Less than 1 CFM

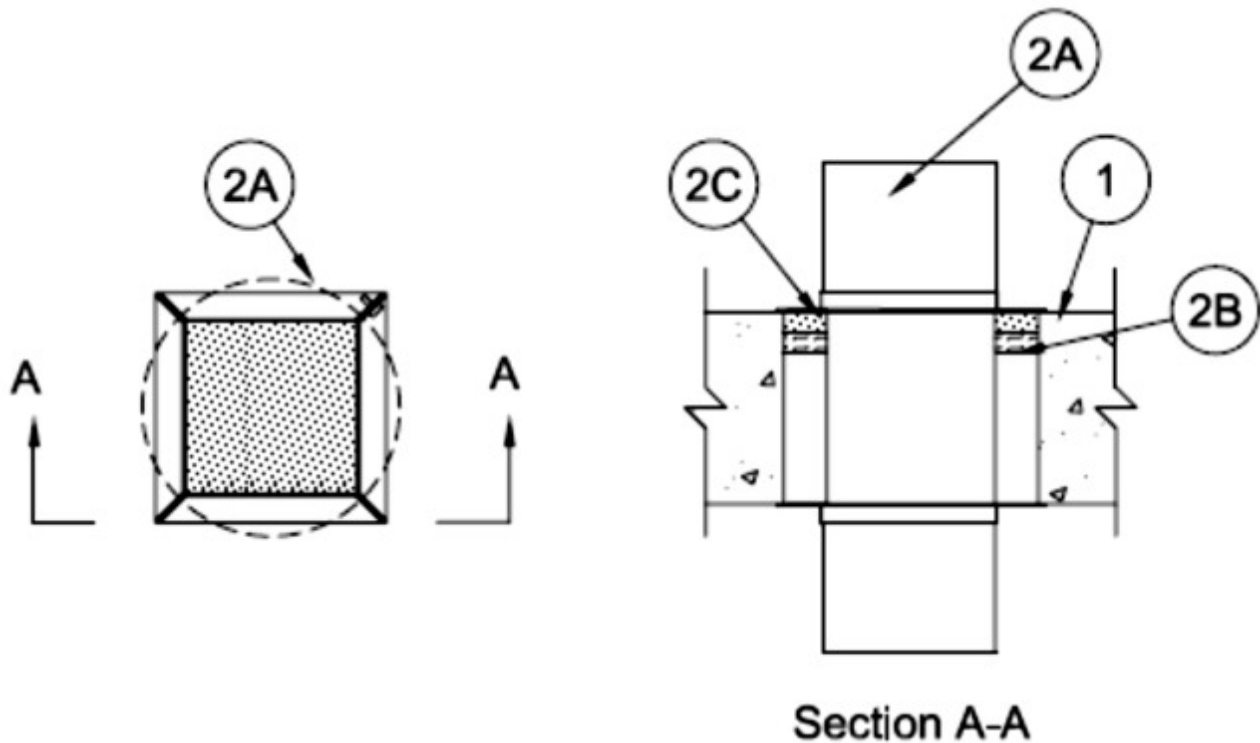

1. **Floor or Wall Assembly** — Min 4-1/2 in. (114 mm) thick reinforced lightweight or normal weight (100-150 pcf or 1600-2400 kg/m<sup>3</sup>) concrete. Wall may also be constructed of any UL Classified **Concrete Blocks\***. Max diam of opening is 6 in. (152 mm).

See **Concrete Blocks** (CAZT) category in Fire Resistance Directory for names of manufacturers.

2. **Firestop System** — The firestop system shall consist of the following:

A. **Firestop Device\*** — Nom 2-1/2 by 2-1/2 by 10 in. (64 by 64 by 254 mm) or 4 by 4 by 10 in. (102 by 102 by 254 mm) powder coated steel transit incorporating internal intumescent material, foam gaskets and mounting flanges. Firestop device to be centered within opening and foam plugs with ends projecting an equal distance beyond each surface of the floor or wall assembly in accordance with the accompanying installation instructions. The annular space between the sides of the firestop device and the periphery of the opening shall a nom 1 in. (25 mm). Firestop device secured in place by means of packing material (Item 2B), fill material, (Item 2C) and steel split mounting flanges sized to accommodate the firestop device. Steel split mounting flanges installed on both sides of floor or wall after installation of fill material and secured to together with supplied steel set screws. Nom 1 in. (25 mm) thick foam plugs installed flush with each end of device on both sides of floor or wall assembly.

**RECTORSEAL** — Biostop ® 2" square Pass Through Device, Biostop ® 4" square Pass Through Device

**B. Packing Material** — Min 1 in. (25 mm) thickness of min 4 pcf (64 kg/m<sup>3</sup>) mineral wool batt insulation or nom 1 in. (25 mm) diam open backer installed into opening immediately prior to the installation of the mounting flanges. Packing material to be recessed from top surface of floor or from both surfaces of wall to accommodate the required thickness of fill material.

**C. Fill, Void or Cavity Materials\* - Caulk or Putty** — Min 1 in. (25 mm) thickness of fill material applied within the annulus between the outer perimeter of firestop device and periphery of opening, flush with top surface of floor or with both surfaces of wall.

**RECTORSEAL** — Biostop 500+ or Firerated putty.

\*Bearing the UL Classification Mark