

## System No. BW-S-0015

December 05, 2005

Assembly Ratings — 1 and 2 Hr (See Item 2)

Joint Width — 3/4 In. Max

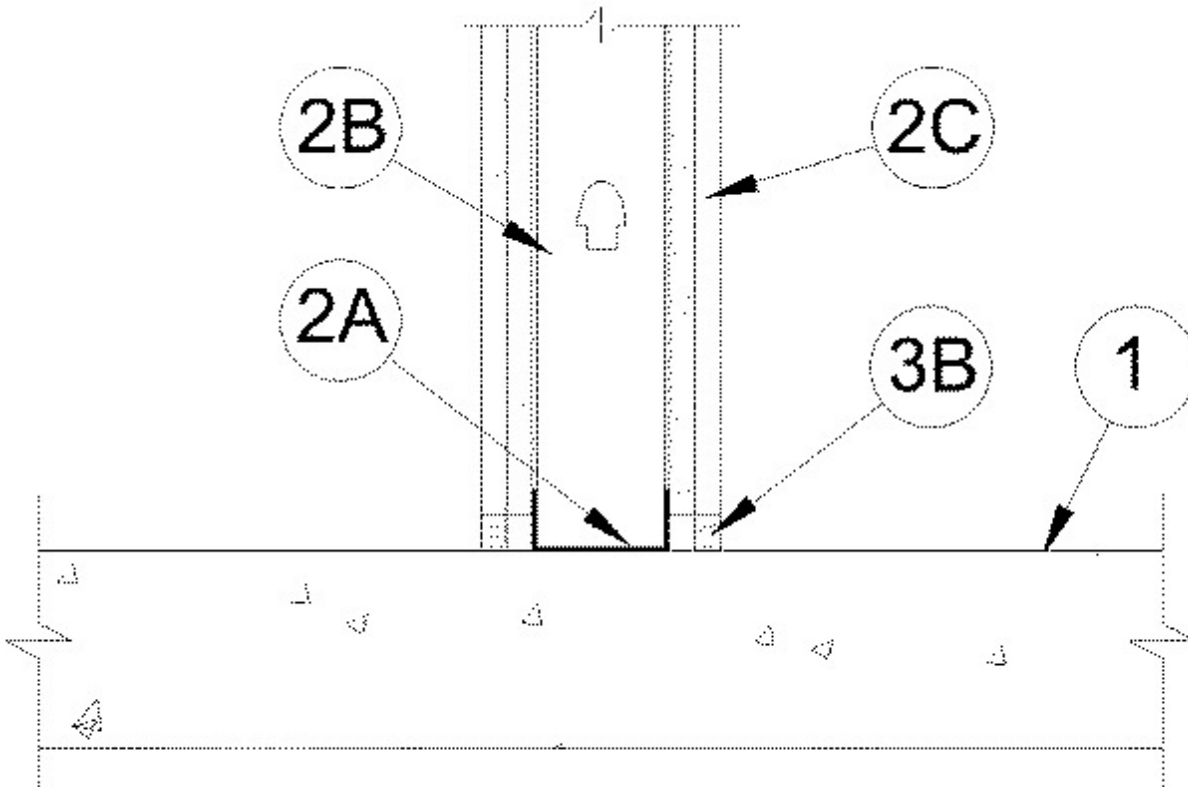

**1. Floor Assembly** — Min 4-1/2 in. (114 mm) thick reinforced lightweight or normal weight (100-150 pcf or 1600-2400 kg/m<sup>3</sup>) structural concrete. Floor may also be constructed of any min 6 in. (152 mm) thick UL Classified hollow-core **Precast Concrete Units\***.

See **Precast Concrete Units** (CFTV) category in the Fire Resistance Directory for names of manufactures.

**2. Wall Assembly** — The 1 or 2 h fire rated gypsum board/steel stud wall assembly shall be constructed of the materials and in the manner specified in the individual U400 or V400 Series Wall and Partition Design in the UL Fire Resistance Directory. In addition, the wall may incorporate a head-of-wall joint system constructed as specified in the HW Series Joint Systems in the UL Fire Resistance Directory. The wall shall include the following construction features:

**A. Steel Floor Runner** — Floor runners of wall assembly shall consist of min No. 25 gauge galv steel channels sized to accommodate steel studs (Item 2B). Floor runners to be provided with min 1-1/4 in. (32 mm) flanges. Runners secured with steel fasteners spaced max 24 in. (610 mm) OC.

**B. Studs** — Min size as specified in the individual design. Studs cut 3/8 to 5/8 in. (10 to 16 mm) less in length than assembly height with bottom nesting in, resting on and fastened to floor runner with sheet metal screws. Stud spacing not to exceed 24 in. (610 mm) OC.

**C. Gypsum Board\*** — Gypsum board installed to a min total thickness of 5/8 or 1-1/4 in. (16 or 32 mm) on each side of wall for a 1 or 2 hr rated wall, respectively. Wall to be constructed as

specified in the individual U400 or V400 Series Design in the UL Fire Resistance Directory, except that a max 3/4 in. (19 mm) gap shall be maintained between the bottom of gypsum board and top of concrete floor.

**The hourly fire rating of the joint system is equal to the hourly fire rating of the wall.**

**3 Fill, Void or Cavity Material\* - Caulk** — Max separation between top of floor and bottom of gypsum board is 3/4 in. (19 mm). Min 5/8 in. (16 mm) thickness of fill material installed on each side of the wall between the bottom of the gypsum board and the top of the concrete floor, flush with each surface of the wall.

**RECTORSEAL** — Biostop 500+, 700, 350i, 750, Biotherm 100 or BF 150+

\*Bearing the UL Classification Mark