

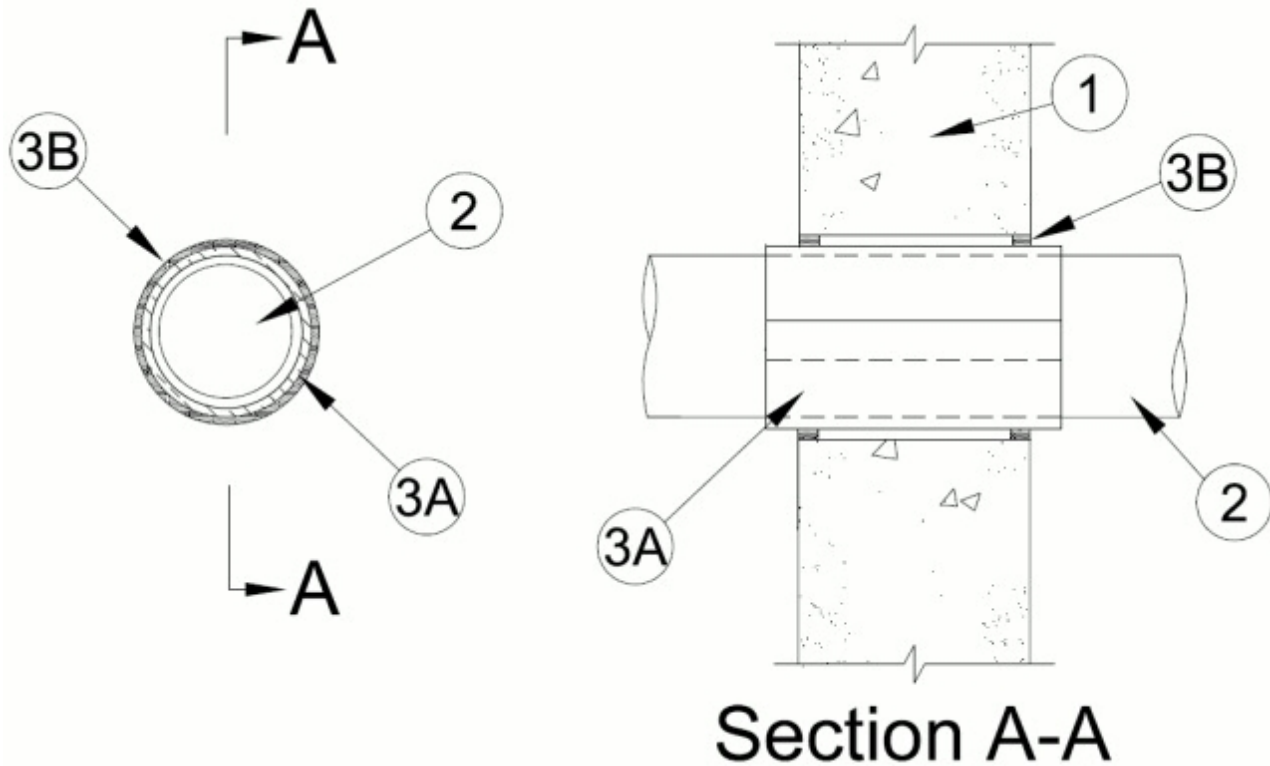

System No. W-J-2274

May 07, 2015

ANSI/UL1479 (ASTM E814)	CAN/ULC S115
F Rating — 2 Hr	F Rating — 2 Hr
T Rating — 2 Hr	FT Rating — 2 Hr
	FH Rating — 2 Hr
	FTH Rating — 2 Hr



System tested with a pressure differential of 50 Pa between the exposed and the unexposed surfaces with the higher pressure on the exposed side.

1. **Wall Assembly** — Min 6 in. (152 mm) thick lightweight or normal weight (100-150 pcf or 1600-2400 kg/m³) concrete. Wall may also be constructed of any UL Classified **Concrete Blocks***. Diam of opening shall be max 1-11/16 in. (43 mm) larger than outer diameter (OD) of through penetrant. Max diam of opening is 8 in. (203 mm).

See **Concrete Blocks** (CAZT) category in the Fire Resistance Directory for names of manufacturers.

2. **Through Penetrants** — One nonmetallic pipe to be installed concentrically within the firestop system. The annular space between the pipe and periphery of opening shall be max 7/8 in. (22 mm). Pipe to be rigidly supported on both sides of the wall assembly. The following types and sizes of nonmetallic pipes may be used:

A. **Polypropylene (PP-R) Pipe** — Nom 6 in. diam - 160 mm OD (or smaller) SDR 17.6 MF Aquatherm Blue Pipe for use in closed (process or supply) or vented (drain, waste or vent) piping systems.

3. **Firestop System** — The firestop system shall consist of the following:

A. Firestop Device — Galv steel sleeve lined with an intumescent material sized to fit the specific diam of the through penetrant. Device to be installed in accordance with the manufacturer's installation instructions along with the following: Device to be wrapped around outer circumference of through penetrant and installed through the annular space of the opening. The device may be temporarily secured by means of tape or tie wires around the outer circumference of through penetrant to allow for installation of the fill material (Item 3B). The device shall be centered within the wall and extend equally beyond each surface of the wall.

RECTORSEAL — FlameSafe® Intumescent Sleeve 68, Metacaulk Intumescent Sleeve 68 or Biostop Intumescent Sleeve 68

B. Fill, Void or Cavity Material* - Sealant — Min 1/2 in. (13 mm) thickness of fill material applied within the annulus, flush with both surfaces of wall.

RECTORSEAL — Metacaulk 1000, Metacaulk 150+, Biostop 500+, Biostop 150+, FlameSafe 1900

* Indicates such products shall bear the UL or cUL Certification Mark for jurisdictions employing the UL or cUL Certification (such as Canada), respectively.